

**Snap-on**  
Muscle Mig System

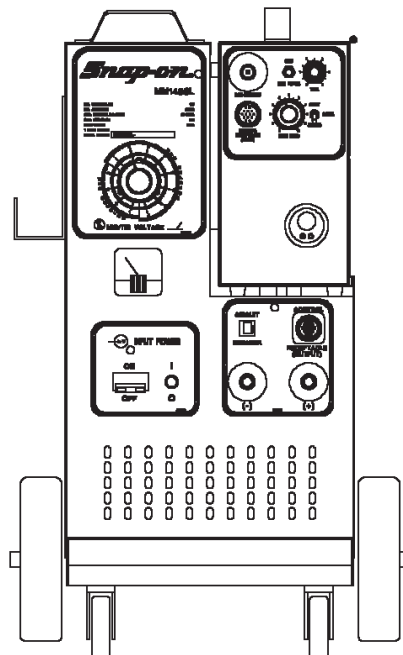

# OWNER'S MANUAL

## MM140SL M.I.G. COMBINATION UNIT



CONGRATULATIONS!

YOU HAVE PURCHASED THE WORLDS FINEST **115 VOLT AC SINGLE PHASE** MIG WELDING SYSTEM AVAILABLE EXCLUSIVELY FROM SNAP-ON TOOLS. THE SNAP-ON MUSCLE MIG SYSTEM MODEL# **MM140SL** IS DESIGNED AND ENGINEERED BY THE PROS FOR THE PROS. UNDER NORMAL CARE THIS SYSTEM WILL PROVIDE YOU WITH YEARS OF UNSURPASSED SERVICE AND MOST IMPORTANTLY PERFORMANCE.



FOR TECH. SERVICE, CALL TOLL-FREE 1-800-232-9353

INSTALLATION  
OPERATION  
MAINTENANCE

## MANUFACTURER'S LIMITED WARRANTY

This equipment is warranted against defects in materials and workmanship for a period of two years from the date of purchase.

### **EXCEPTION: THE MIG TORCH IS WARRANTED FOR A PERIOD OF 30 DAYS FROM THE DATE OF PURCHASE.**

Should the equipment become defective for such reason, the Manufacturer will repair it without charge, if it is returned to the Manufacturer's factory, freight prepaid. This warranty does not cover: (1) failure due to normal wear and tear; (2) consumable parts, such as, but not limited to, torch contact tips, gas cups and insulating bushings; (3) damage by accident, force majeure, improper use, neglect, unauthorized repair or alteration; (4) anyone other than the original purchaser.

THIS LIMITED WARRANTY IS IN LIEU OF ALL OTHER WARRANTIES, EXPRESS OR IMPLIED. THE MANUFACTURER SHALL NOT BE LIABLE FOR ANY INJURY TO PERSONS, INCLUDING DEATH; OR LOSS OR DAMAGE TO ANY PROPERTY, DIRECT OR CONSEQUENTIAL, INCLUDING, BUT NOT LIMITED TO, LOSS OF USE, ARISING OUT OF THE USE, OR THE INABILITY TO USE, THE PRODUCT. THE USER ASSUMES ALL RISK AND LIABILITY WHATSOEVER IN CONNECTION WITH THE USE OF THE PRODUCT, AND BEFORE DOING SO, SHALL DETERMINE ITS SUITABILITY FOR HIS INTENDED USE, AND SHALL ASCERTAIN THE PROPER METHOD OF USING IT.

SOME STATES DO NOT ALLOW LIMITATIONS ON HOW LONG AN IMPLIED WARRANTY LASTS, OR THE EXCLUSIONS OR LIMITATIONS OF INCIDENTAL OR CONSEQUENTIAL DAMAGES. SO THE ABOVE LIMITATIONS OR EXCLUSIONS MAY NOT APPLY TO YOU. THIS WARRANTY GIVES YOU SPECIFIC LEGAL RIGHTS, AND YOU MAY HAVE OTHER RIGHTS WHICH MAY VARY FROM STATE TO STATE.



## WARNING

**ARC WELDING CAN BE INJURIOUS TO OPERATOR AND PERSONS IN THE WORK AREA — CONSULT INSTRUCTION MANUAL BEFORE OPERATING.**

### **ELECTRIC SHOCK can kill.**

- Do not touch electrodes or other electrically live parts.
- Insulate yourself from work and ground.
- Install and ground machine in accordance with the National Electrical Code and local code(s). Read Operating Manual before installing or operating.
- Do not operate with protective covers, panels, or guard removed.
- Disconnect input power before servicing.
- Only qualified personnel should install, use, or service this equipment.

### **ARC RAYS can injure your eyes and burn skin.**

- Wear correct eye, ear, and body protection while welding.

### **FUMES AND GASES can be dangerous to your health.**

- Use enough ventilation and/or exhaust at the arc.
- Keep your head out of fumes.
- Do not breathe fumes.

### **READ AND UNDERSTAND THE MANUFACTURER'S INSTRUCTIONS AND YOUR EMPLOYER'S SAFETY PRACTICES.**

See American National Standard Z49.1, "Safety in Welding and Cutting", published by the American Welding Society, 2501 N.W. 7th St., Miami, Florida 33125; OSHA Safety and Health Standards, 29 CFR 1910 available from U.S. Dept. of Labor, Wash., D.C. 20210.

## TABLE OF CONTENTS

<b>ELECTRICAL SUPPLY REQUIREMENTS .....</b>	<b>1</b>
<b>INTRODUCTION .....</b>	<b>2</b>
<b>DESCRIPTION, SPECIFICATIONS .....</b>	<b>3</b>
<b>CHECK LIST (CONTENTS) .....</b>	<b>4</b>
<b>INSTALLATION .....</b>	<b>4</b>
<b>OPERATION .....</b>	<b>8</b>
<b>MAINTENANCE .....</b>	<b>13</b>
<b>TROUBLE SHOOTING CHART .....</b>	<b>15</b>
<b>CONNECTING FLEX-TIG OR SPOOL GUN .....</b>	<b>20</b>
<b>LINER INSTALLATION .....</b>	<b>21</b>
<b>PARTS BREAKDOWN - MIG TORCH .....</b>	<b>22</b>
<b>OPTIONS - FLEX-TIG OR SPOOL GUN .....</b>	<b>24</b>
<b>PARAMETER CHARTS .....</b>	<b>25</b>

# ELECTRICAL SUPPLY REQUIREMENTS FOR THE MM140SL

Ensure that there is a **115** volt single phase, **20** amp electrical supply within easy reach of the unit. The input cable supplied is 20 feet long. A 50 foot cable is an optional extra. The plug which is factory installed is suitable for use up to 120 amps of output. The plug must be changed if the welder is used above 120 amps of output. Attach a suitable plug making sure the green wire is attached to ground. Refer to boxes below with the **WARNING** and **NOTE** headings for more information. All wiring should be performed by a qualified electrician.

## WARNING

To conform to the National Electrical Code, the power input plug must be changed if this unit is to be operated on a 20 amp circuit or higher.

Never change fuses or circuit breakers to a higher value than the wires and outlet are designed for.

Breaker size	-	Wire size
15 Amp		14 Gauge
20 Amp		12 Gauge
30 Amp		10 Gauge

Do not rely on the circuit breaker built into the MM140SL to protect your wiring. This circuit breaker protects the MM140SL internal wiring only.

Do not use undersized extension cords. Follow the cord manufacturer's recommendations as to current carrying capacities.

Make sure all electrical wiring is installed by a qualified electrician.

## NOTE

The maximum output of the MM140SL will be limited by the size (amp rating) of the circuit used.

Operation on a 15 amp circuit (14 gauge wire) will limit maximum output to 100 amps.

Operation on a 20 amp circuit (12 gauge wire) will limit maximum output to 120 amps.

Operation on a 30 amp circuit (10 gauge wire) will result in maximum output of 140 amps.

MM140SL output will be limited also by low input voltage (less than 120 volts), long input cords and use of extension cords.

## INTRODUCTION

The Snap-on Tools **MM140SL** is a combination welding power source, remote feed unit, MIG torch and accessory package. It operates on 115 volts AC input current and is designed to meet the requirements of autobody repair shops. The **MM140SL** produces fusion welds by the Gas Metal Arc Welding process (GMAW or MIG), on steel and aluminum up to "1/4" thick, using .023" through .045" steel wire and .025" through 3/64" aluminum wire with the optional MHG5-B spool gun. **(optional liners must be purchased to cover given wire sizes)**. Heavier sections can be easily welded using slightly different techniques.

The number of controls on the unit have been reduced to assist inexperienced operators to learn MIG welding. This facilitates rapid set up for welding various thicknesses of material requiring various heat inputs. The VOLTAGE control adjusts the welding voltage and the WIRE FEED control adjusts the speed of the wire feed motor.

### THE MIG PROCESS AS APPLIED TO THE MM140SL

The MIG process uses a bare, consumable electrode in the form of spooled wire, which is fed by a controllable speed feed unit through the cable and torch to the weld. The emerging wire and the weld are shielded by a stream of CO<sub>2</sub>, Argon, or a mixture of the two, which prevents oxidation of the molten weld puddle. The gas shield enables high quality welds to be made without the use of flux, eliminating the need for slag or flux removal after the weld is completed.

The consumable electrode wire is melted and transferred to the weld puddle by "short arc" or "dip" transfer mode.

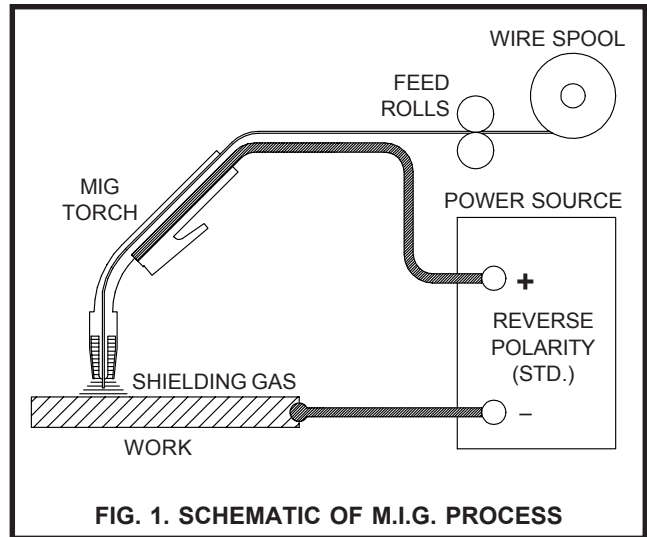

### SHORT ARC OR DIP TRANSFER

Short arc transfer occurs at 12 to 22 arc volts (voltage while welding), depending on wire size. Welding commences as the arc is struck and a weld pool is formed. The tip of the electrode wire dips into the pool and causes a short circuit. The short circuit current flow causes a rapid temperature rise in the electrode wire and the end of the wire is melted off. An arc is immediately formed between the tip of the wire and the weld pool, maintaining the electrical circuit and producing sufficient heat to keep the weld pool fluid. The electrode continues to feed and again dips into the pool.

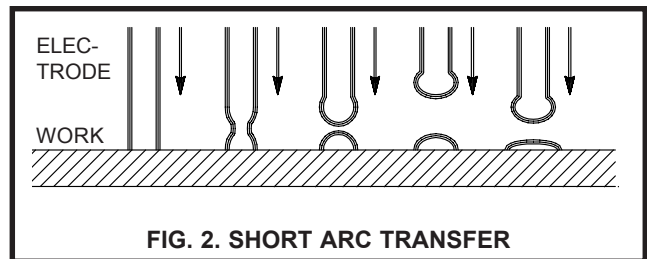

This sequence of events is repeated up to 200 times per second. Short arc transfer is suitable for positional welding. The heat input to the workpiece is kept to a minimum which limits distortion and makes possible the welding of thin sheet material.

## DESCRIPTION

The **MM140SL** consists of a combination MIG welding power source and remote feed unit, a MIG torch with 10 foot cable, a fifteen foot feeder control cable, a fifteen foot work cable with clamp, a twenty foot power input cable, a gas regulator - flowmeter, a torch accessory kit, and a built-in cylinder rack and industrial wheel kit.

Welder controls are simple and clearly marked. The output voltage is controlled by a twelve position tap switch, providing **4 TIG** and **8 MIG** voltage selections. Wire feed speed is controlled by the wire speed potentiometer.

A **SPOT WELD** control switch and adjustable timer circuit provides Consumable MIG Spot Welding capabilities of light gauge steel.

## SPECIFICATIONS

**PART NUMBER:** **MM140SL**

### INPUT POWER REQUIREMENTS:

Voltage 115 volts AC  
Phase single phase  
Frequency 50/60 hertz  
Current (see below)

### OUTPUT POWER @ 100% Duty Cycle:

15 Amps Input Current= 100 Amps  
20 Amps Input Current= 120 Amps  
30 Amps Input Current= 140 Amps

### DUTY CYCLE TIME PERIOD:

10 minutes

### OPEN CIRCUIT VOLTAGE:

18 - 33 volts DC

**ARC VOLTAGE:** 14 - 26 volts DC

### WELD CURRENT RANGE:

30 - 140 amps

## SPECIFICATIONS (Cont.)

### REMOTE FEED UNIT

Input Voltage 28 VAC  
Wire Feed Speed Range: 50-800 IPM

### DUTY CYCLE - SPOT WELDING:

30 X 2 second spots per 10 minute period

### SPOT WELD TIME:

0 TO 3 seconds

### WIRE TYPES:

mild steel,  
stainless steel, aluminum,  
bronze, flux cored,  
flux cored - gasless

### WIRE SIZES:

.023" - .045" steel,  
3/64" aluminum,  
(.023" - 3/64" alum. w/spool gun)  
.030" - .035" bronze,  
.035" - .045" flux cored  
(gas shielded or gasless)

### SHIELDING GASES:

For Steel CO2 or Argon/CO2 mix  
For Aluminum, Bronze Argon  
For Stainless Steel  
98% Argon/2% Oxygen  
For Flux cored CO2 or  
Argon/CO2 mix

### DIMENSIONS:

Height 32-1/4 in. (81.9 cm.)  
Width 14-1/2 in. (36.8 cm.)  
Depth 26-1/4 in. (66.7 cm.)  
Weight 155 lbs. (70.4 kg.)

## TORCH SPECIFICATIONS

**NECK ANGLE:** 60 degrees

**LEAD LENGTH:** 10 feet

**OVERALL LENGTH:** 10 feet

**COOLING METHOD:** gas (air)

### RATING - DUTY CYCLE:

With Argon/CO2 gas 150 amps @ 100%  
With CO2 gas 200 amps @ 100%

## CHECK LIST

THE SNAP-ON TOOLS MM140SL INCLUDES THE FOLLOWING:

- 1- Combination Power Source/Remote Feed Unit
- 1- Cylinder Rack/Industrial Wheel Kit
- 1- 15 foot Feeder Control Cable assy (FCA-15).
- 1- 15TG10 MIG Torch with adjustable nozzle
- 1- 20 foot Power Input Cable with Plug
- 1- 15 foot Ground Cable and Clamp
- 1- 200PK-1 Parts Kit
- 1- GR-FM Gas Regulator/Flowmeter
- 1- Nozzle, 1/2 in. orifice (installed on MIG torch)
- 1- Contact Tip, for .030 in. wire (installed on MIG torch)
- 1- ER70S-6-30-3, Sample Spool of .030 Steel Wire

ITEMS REQUIRED FOR MIG WELDING WHICH ARE NOT PROVIDED WITH THE MM140SL

- 1. Full cover welding helmet with proper colored lens (shade 9 to 11 depending on operator's preference).
- 2. Proper shielding gas and cylinder.
- 3. Leather welding gloves.
- 4. **115 volt single phase AC power.**
- 5. Other personal protective equipment which may vary to match the welding being performed.

## INSTALLATION

### POSITIONING THE UNIT

Locate the unit adjacent to the welding area and position it so there is adequate clearance all around for ventilation and maintenance.

## ELECTRICAL SUPPLY

Follow the Electrical Supply Requirements on [page 1](#).

### INSTALLING THE FEEDER CONTROL CABLE ASSEMBLY

- 1. Uncoil the cable assembly.

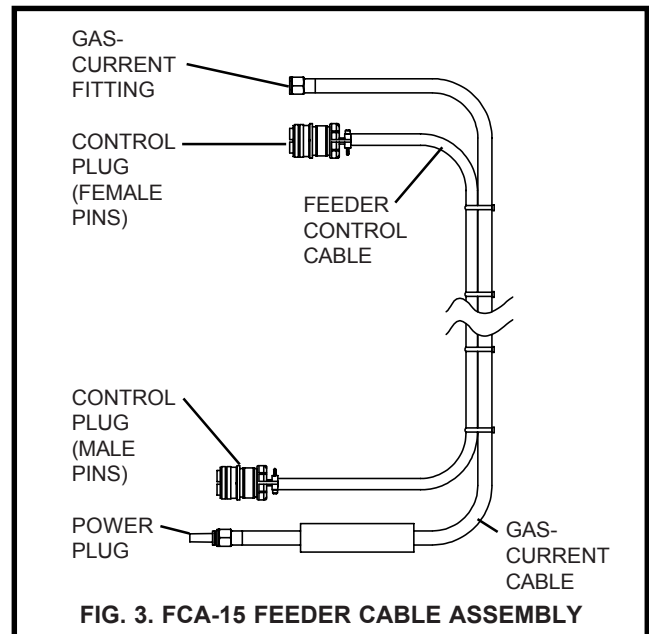

- 2. With the proper size wrench attach the gas-current fitting to the gas-current terminal (located on the front of the feed unit).
- 3. Connect the control plug (female pins) on to the control receptacle (INPUT) and tighten (located on the front of the feed unit).

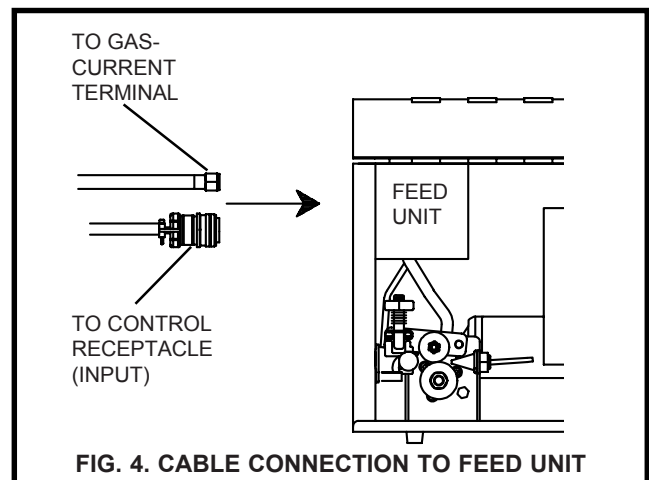

## INSTALLING THE FEEDER CONTROL CABLE ASSEMBLY (Cont.)

4. Plug the power plug into the positive (+) terminal (located on the front of the welding machine).
5. Connect the control plug (male pins) onto the control receptacle (OUTPUT) and tighten (located on the front of the welding machine).

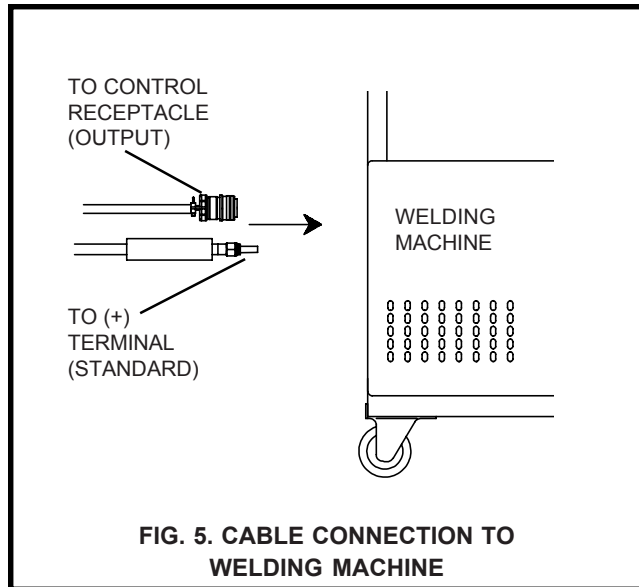

## SHIELDING GAS CONNECTIONS

1. Place a cylinder of the appropriate shielding gas in the rack at the rear of the machine and secure it with the chain provided.
2. Rapidly open and close the cylinder valve. This will purge dust and foreign matter from the valve.

### CAUTION

Take care to point the valve outlet away from yourself or other people, as escaping high pressure gas may be dangerous.

3. Attach the gas regulator - flow-meter supplied with this unit, to the cylinder valve using a suitable wrench.

### NOTE

If this unit is to be used with 100% CO<sub>2</sub> shielding gas, an optional gas regulator coupler is required.

4. Fit the gas hose from the welding machine to the regulator outlet fitting and tighten it with a wrench. Open the cylinder valve. When welding steel, the gas flow rate is 30 CFH. When welding aluminum, the gas flow rate is 40 CFH.

### NOTE

The **MM140SL** must be turned "ON" and the MIG torch trigger depressed, before the gas flow rate can be adjusted.

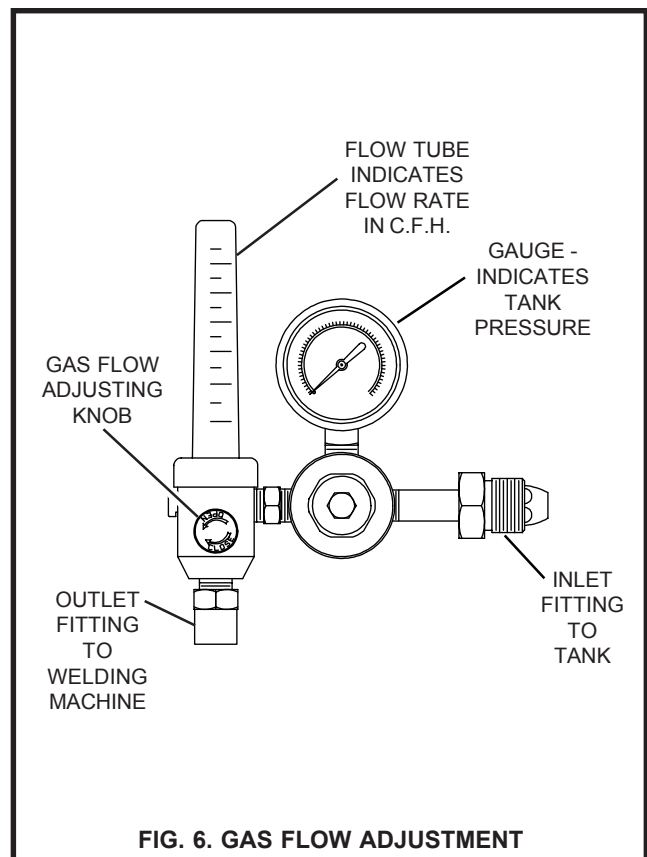

## INSTALLATION (Cont.)

### TORCH CONNECTION

1. Open the access door of the Feed unit to its fullest extent.
2. Back out the thumb screw located on the drive assembly mounting bracket inside the machine. Insert the MIG torch into the torch panel mount on the front panel and **TIGHTEN THE THUMB SCREW.**

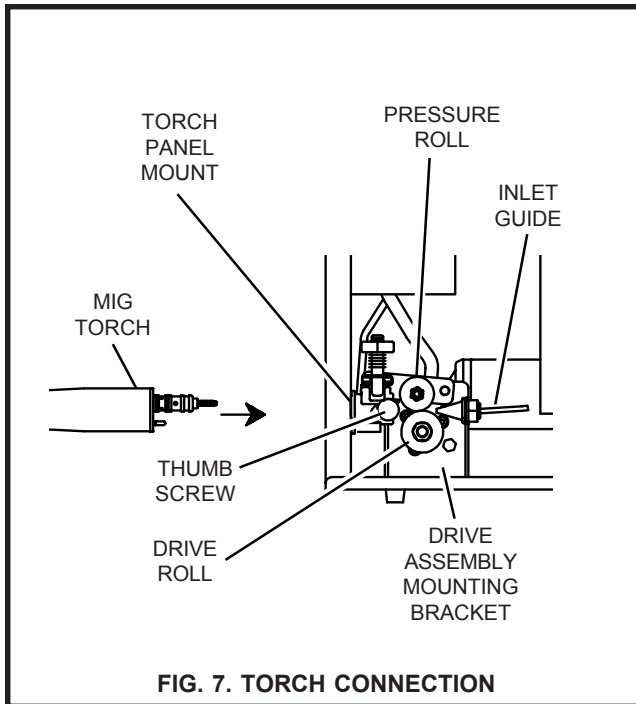

FIG. 7. TORCH CONNECTION

### FITTING AND THREADING THE ELECTRODE WIRE - ALWAYS USE ER70S-6 WELDING WIRE WHEN WELDING STEEL.

1. Remove the wire spool clip from the spool hub.
2. Unpack the spool of welding wire from its protective packaging.

3. Place the spool of ER70S-6 welding wire onto the hub. The wire is fed off the bottom of the spool.

### CAUTION

Look for wire protruding from the center of the spool. The protruding wire is electrically HOT during welding and must not touch the machine.

4. Replace the spool clip on the hub.
5. Unlatch the pressure roll arm and swing it open.
6. Make sure the double v-groove drive roll is installed to match the wire size. To change the wire size setting, remove the drive roll, turn it over and reinstall it on the shaft.
7. Release the wire from the spool and trim off the kinked end with wire cutters. The wire must be straight when it enters the inlet guide.

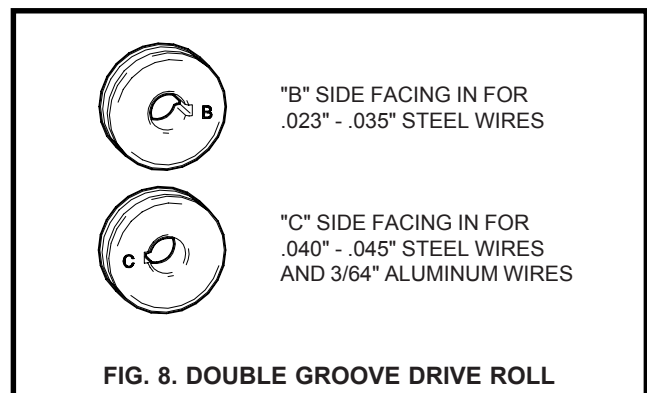

"B" SIDE FACING IN FOR  
.023" - .035" STEEL WIRES

"C" SIDE FACING IN FOR  
.040" - .045" STEEL WIRES  
AND 3/64" ALUMINUM WIRES

FIG. 8. DOUBLE GROOVE DRIVE ROLL



## FITTING AND THREADING THE ELECTRODE WIRE (Cont.)

8. Thread the electrode wire through the inlet guide, over the feed roll and into the outlet guide. Ensure that the wire locates in the feed roll groove. Do not allow the wire on the spool to loosen.
9. Close and relatch the pressure roll arm.
10. Stretch the torch cable straight out in front of the machine making sure there are no kinks. Remove the nozzle and contact tip from the torch.
11. Turn on the circuit breaker on the front of the machine. The cooling fan will start and the "ON" indicator light will illuminate. Set the MIG/TIG VOLTAGE control switch to "MIG 3" and the WIRE SPEED control to "5". Pull the trigger on the MIG torch. The wire feed system will start and wire will be fed through the cable liner and torch. If the wire does not feed, or appears to slip, tighten the pressure roll arm adjusting nut. Feed the wire until it protrudes from the front of the torch approximately six inches.

### CAUTION

Keep hands and face away from the front of the torch and do not allow the wire to contact ground. The wire is electrically **HOT** when the torch trigger is actuated.

## FITTING AND THREADING THE ELECTRODE WIRE (Cont.)

12. Install the contact tip over the protruding wire and tighten it firmly using a proper size wrench. Make sure the tip is the correct size for the wire being used.
13. Install the nozzle on the torch. For steel, the contact tip should be flush or stick out up to 1/16 inch beyond the end of the nozzle. For aluminum, the contact tip should be recessed 1/8 to 1/4 inch inside the nozzle. Using wire cutters, trim off the wire so the stickout is approximately 1/4 inch for steel or 1 inch for aluminum. For aluminum, the end of the wire should be bent over so it does not **JAM** into the work. This is called a "scratch start".

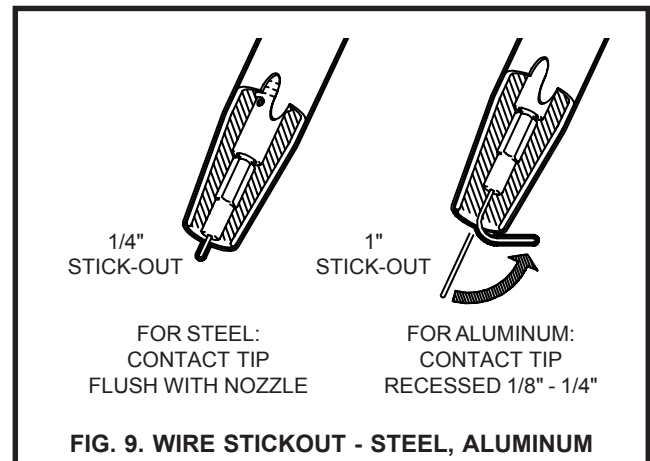

14. For steel welding only, spray anti-spatter compound inside the nozzle and on the outside of the contact tip. For aluminum or stainless steel welding, **NO** anti-spatter compound can be used as it will contaminate the weld.

## WIRE FEED PRESSURE ROLL ADJUSTMENT

The wire feed pressure roll is adjusted to the proper setting at the factory, prior to delivery. It may be necessary to readjust the setting as components "seat in" or when changing to a different diameter wire. To check for proper roll pressure, hold the torch in one hand and the wire between two fingers of the other hand. Pull the torch trigger. If the wire continues to feed when firm pressure is applied to the wire, the pressure roll adjusting nut should be backed off until the feed rolls start to slip. If the wire will not feed with very little pressure applied, the pressure roll adjusting nut should be tightened.

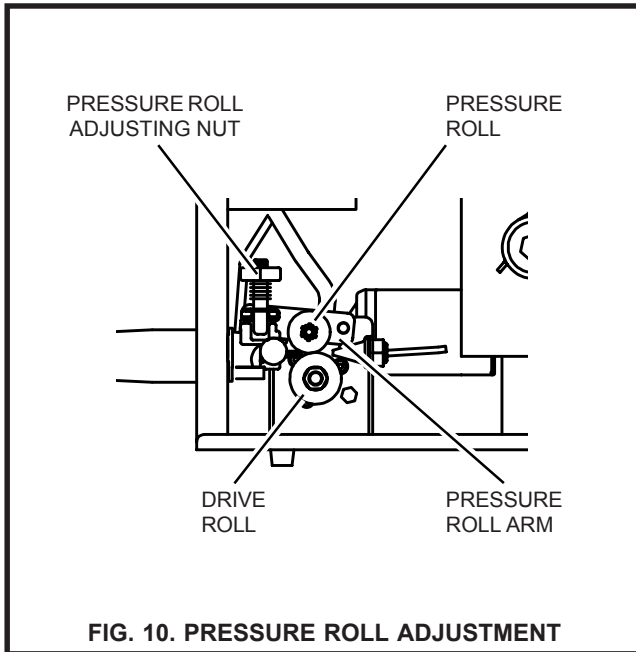

## WORK (GROUND) CABLE

Uncoil the work (ground) cable and plug it into the negative (-) terminal on the machine.

## OPERATION

The following operating instructions and detailed setup procedures enable an operator without previous experience to produce quality fusion welds. It is recommended that an operator without prior experience with this equipment, first practice on scrap metal of the same type and thickness as the material to be welded.

## OPERATING SEQUENCE

1. Make sure that the pieces of metal to be welded are free of grease, dirt, paint and scale. Use a wire brush to remove paint and scale. Paint must be completely removed to bare metal. Grease and oil could burn and cause a fire or safety hazard. Failure to clean the metal properly will result in erratic and porous welds.
2. Install the unit as directed in the installation instructions and make sure the work clamp is firmly attached to a cleaned area on the workpiece to be welded.
3. Open the shielding gas cylinder valve. Press the torch trigger and listen for gas flow.

## CAUTION

The welding wire will feed when the trigger is actuated. Take care that the wire is not directed to hit yourself or anything that is common to the work cable on the welder.

## PROCESS SELECTION

The following controls are located on the front of the **MM140SL**.

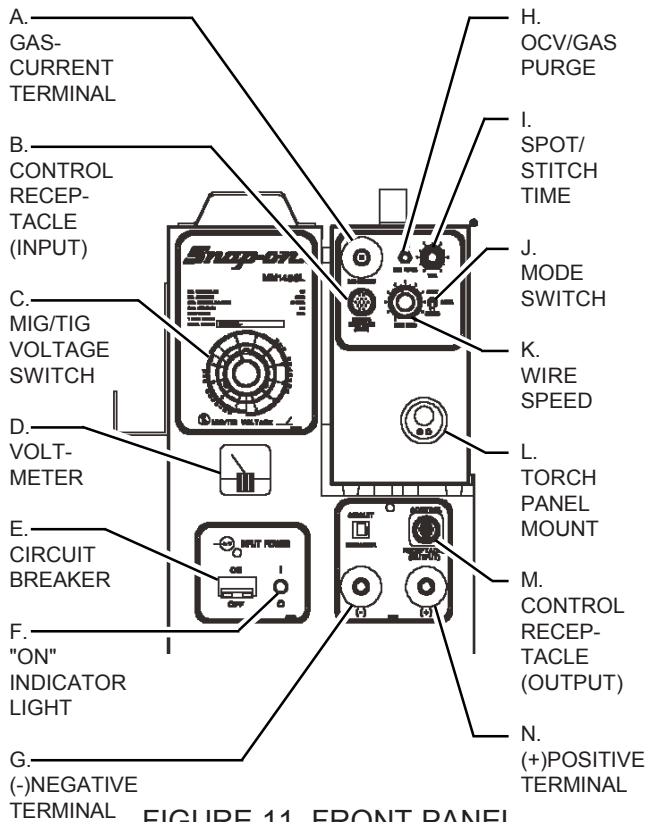

FIGURE 11. FRONT PANEL

### A. GAS-CURRENT TERMINAL

Single terminal connection for gas and current from welding machine.

### B. CONTROL RECEPTACLE (INPUT)

Input receptacle for wire feed voltage, trigger circuit and wire speed control from welding machine.

### C. MIG/TIG VOLTAGE SWITCH

Twelve position switch provides "4" TIG (requires optional FLEX TIG) and "8" MIG voltage settings.

### D. VOLTMETER

Indicates open circuit voltage when torch trigger switch is activated and arc (welding) voltage during welding.

### E. CIRCUIT BREAKER

Primary power switch and overload protection device.

### F. "ON" INDICATOR LIGHT

Illuminates when the circuit breaker on the machine is "ON".

### G. (-)NEGATIVE TERMINAL

Negative output terminal. The work cable is plugged into this terminal during standard welding operation. The Power plug can be inserted into this terminal for straight polarity welding on very light sheet metal, or for using flux cored gasless wire.

### H. OCV/GAS PURGE

Operates the gas solenoid to purge the lines of impurities prior to welding. Pressing the switch also causes open circuit voltage to be registered on the power source voltmeter.

## CAUTION

Torch is electrically **HOT** when switch is actuated.

### I. SPOT/STITCH TIME

After the torch trigger is actuated, the timer allows the wire to feed and the gas and power to flow for the time selected. The Mode Switch must be set in "SPOT" or "STITCH" position for timing operation.

### J. MODE SWITCH

Controls mode of operation of welding machine. "CONT." position is for normal, continuous welding operation. "SPOT" position puts the spot timer in the circuit for automatic MIG Consumable Spot Welding. "STITCH" position is used for stitch welding on very light materials.

### K. WIRE SPEED

Potentiometer controls speed of wire drive motor to give wire speed of 50 to 800 inches per minute.

(continued on following page)

## PROCESS SELECTION (Cont.)

### L. TORCH PANEL MOUNT

Combination power output, contactor switch connection, gas supply connection, and wire feed output in a single unit.

### M. CONTROL RECEPTACLE (OUTPUT)

Output receptacle for wire feed voltage, trigger circuit and wire speed control out to the remote feed unit.

### N. (+) POSITIVE TERMINAL

Positive output terminal from the welder DC power source. The Power plug is inserted into this terminal for standard welding operation. The work cable can be plugged into this terminal for straight polarity welding on very light sheet metal, or for using flux cored gasless wire.

## WELDING

Optimum control settings will vary according to the thickness of the metal, the type of joint, operator preference, etc. Best results can be obtained through experience with the welding machine or by making trial welds. Select some sample material of the same type and thickness as the material to be welded. Set the welding controls (using the parameter chart located on the door of the feed unit or on page 25) for optimum results using the sample material thickness and wire size being used as a starting point, weld until experience is gained using the unit.

## CONTINUOUS WELDING ON STEEL

1. Trim the electrode wire to leave approximately 1/4 inch stickout beyond the end of the contact tip and install the welding nozzle. The contact tip should be flush or stick out up to 1/16 inch beyond the end of the nozzle.

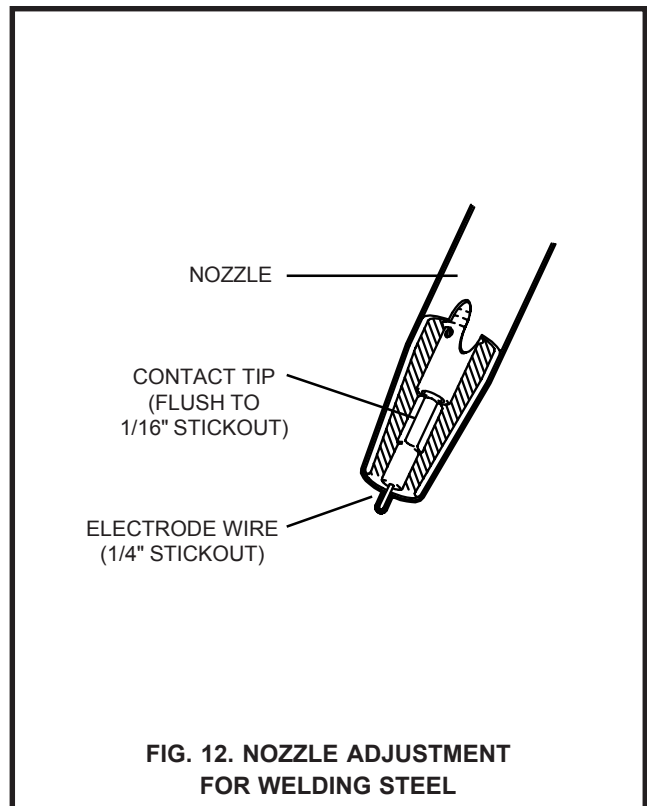

2. Spray the inside of the nozzle and the outside of the contact tip with anti-spatter compound.
3. Locate the torch over the joint to be welded with the contact tip approximately 3/4 inch from the work surface.
4. Use a welding helmet with a shade 9 to 11 filter lens, depending on operator preference.

### NOTE

When welding steel, the ideal position for holding the torch is inclined approximately 30 degrees towards the direction of travel. This allows the arc to be seen easily, resulting in greater control of the weld pool. Most right-handed weldors move from left to right. This method, known as forehand welding, provides a gas shield for the cooling weld puddle and helps in obtaining an oxidation free weld deposit.

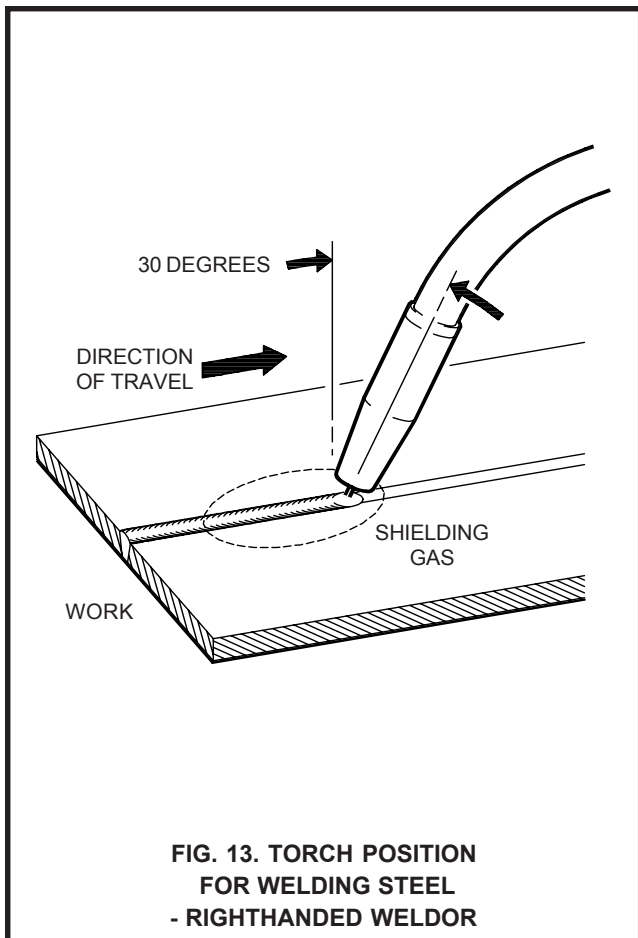

5. Squeeze the torch trigger. The wire will feed and an arc will be established. As the weld is deposited, move the torch slowly along the weld seam at a constant speed, while maintaining a constant arc length and a constant tip-to-work distance.

**CONTINUOUS WELDING ON ALUMINUM**  
 (Optional Nylon liner and 100% Argon shielding gas are required)

1. Trim the electrode wire, leaving approximately 1 inch stickout beyond the end of the nozzle. Bend the wire over as shown, to allow for a scratch start. The contact tip should be recessed inside the nozzle approximately 3/8 inch. This helps prevent the welding wire from burning back to the contact tip.

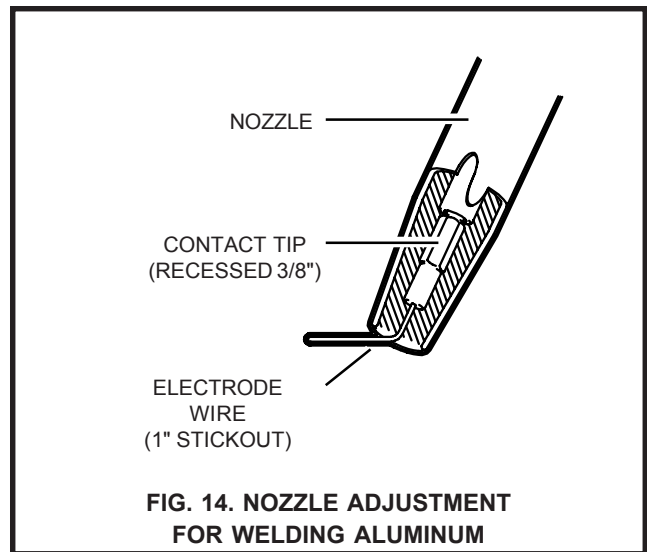

2. DO NOT spray any anti-spatter material on the torch or base metal and DO NOT attempt to lubricate the aluminum wire in any way. Weld contamination will occur unless the wire, base metal, torch and work area are kept clean.
3. Bring the torch nozzle to 1/2 to 5/8 inch from the workpiece. The recommended position of the torch and direction of travel for welding aluminum are shown in the following illustration.

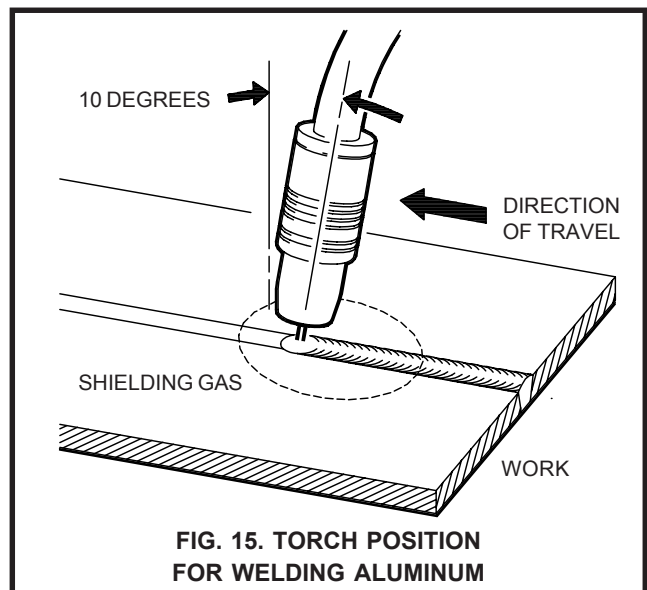

4. Follow steps 4 and 5 as in "Continuous Welding on Steel".

## MIG SPOT WELDING ON STEEL

### NOTE

MIG Spot Welding is NOT recommended for aluminum.

1. Trim the electrode wire so the stickout from the contact tip will be flush with the nozzle face, and fit the spot nozzle in place.
2. Set the VOLTAGE on the welder around 20 volts, the WIRE FEED control "8", the MODE Switch to "SPOT", and the TIME control to "3", then adjust the controls to obtain a perfect weld.
3. Locate the torch on the area to be welded and press the nozzle firmly against the work to hold the metals in place.
4. Guard the eyes against stray arc flash. A weldor's helmet is not necessary when spot welding, however, care must be taken to avoid looking at the arc.
5. Activate the torch trigger to start the weld sequence. When the timer switches off the weld current, release the trigger but maintain firm contact between the torch and work. Wait one second for the weld puddle to solidify, then move to the next spot position. If the wire "freezes" in the puddle, a quick squeeze of the torch trigger will melt it off.
6. To ascertain a good spot weld, look at the back side of the welded material. A small melt-through of approximately 1/16 inch diameter is ideal.

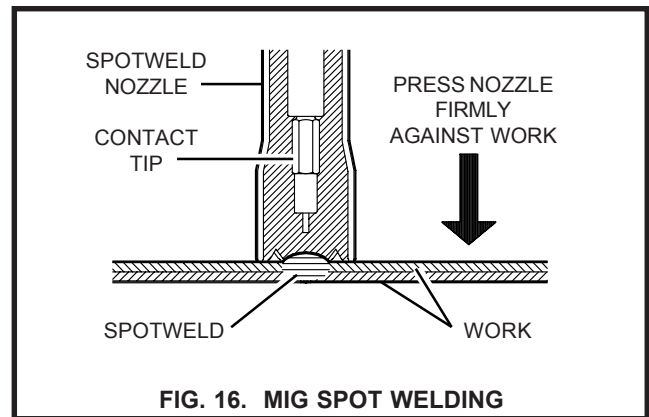

FIG. 16. MIG SPOT WELDING

## STITCH WELDING ON STEEL

### NOTE

Stitch Welding is used for very light material.

1. Set MODE Switch to "STITCH".
2. Adjust the TIME control to set the time the welder is "on" and feeding wire. The lower the setting, the shorter the "on" time and the faster the unit cycles on and off.
3. Weld using "Continuous Welding" torch position and direction of travel.

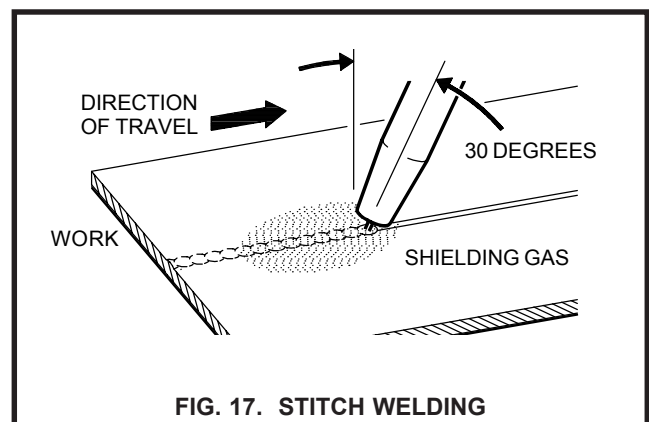

FIG. 17. STITCH WELDING

## OPERATING HINTS

### BURN BACK

In the event the welding wire burns back into the contact tip:

1. Remove the nozzle from the torch.
2. Unscrew the contact tip from the gas diffuser using a pair of pliers as the tip will be very hot.
3. Free the wire from the contact tip and clean the end of the tip so the new wire will slide smoothly through the hole. DO NOT use a drill or reamer to clean the hole as they will enlarge it and cause an erratic arc. Replace the contact tip if it is badly damaged.
4. Install the contact tip in the torch and tighten it firmly with an appropriate wrench.
5. Reinstall the torch nozzle.
6. If the wire continues to burn back, check for erratic wire feed, or speed up the wire by increasing the WIRE SPEED control setting or reducing the VOLTAGE control setting.

### SPATTER

Before beginning to weld and periodically during welding, the torch nozzle must be removed and the spatter (small globules of melted metal) cleared from the inside of the nozzle and the outside of the contact tip and the gas diffuser. Spatter buildup between the contact tip and the nozzle can cause a short circuit and consequently, failure of the torch or welding machine. The frequent use of anti-spatter spray will help prevent the adherence of spatter to the torch components.

### NOTE

DO NOT use any anti-spatter spray when welding aluminum or stainless steel.

Restricted gas flow, holding the torch too far from the work piece, and the use of CO2 gas rather than 75% Argon - 25% CO2 will increase the spatter levels.

## MAINTENANCE

To ensure that this equipment maintains its operating efficiency, the following maintenance schedule and procedures are recommended. These routines should be performed regularly by the operator.

**REGULARLY** - Usage and shop conditions determine frequency.

1. Remove and clean the torch nozzle and contact tip. The use of anti-spatter spray will reduce the adherence of spatter and makes its removal easier.
2. Blow out the torch liner prior to the installation of each new spool of wire. The contact tip and gas diffuser must be removed, but it is not necessary to remove the liner.
3. If the torch cable assembly is bent severely, a kink may develop in the steel liner. This can cause wire feeding problems so a new liner should be installed.

### **WEEKLY**

Remove dirt and dust from the wire feed compartment. Use low pressure dry compressed air.

(continued on following page)

## MAINTENANCE (Cont.)

2. Remove dirt and metal deposits from the grooves in the feed roll. If the grooves are badly worn, the feed roll should be replaced. If the pressure roll does not turn freely, it should be replaced.
3. Check all gas fittings for leaks. Tighten or repair as required.

### EVERY SIX MONTHS

1. Disconnect the welder from its main power supply.
2. Remove the machine's side panels.
3. Using low pressure dry compressed air, remove dust and dirt from all components.
4. Check for loose or frayed wiring. Particularly check welding current wire connections.
5. Replace torch liner if necessary.

### RECOMMENDED CUSTOMER SPARE PARTS

The Snap-on Tools **MM140SL** is a machine of proven design and reliability. Following is a list of consumable items recommended as spare parts for this unit.

contact tips ..... M3-T30, etc.  
gas nozzles ..... M3T-N50  
nozzle insulators ..... M3T-B  
gas diffusers ..... M3T-D  
steel liner(.020-.030) .. M103L-B  
steel liner(.035-.045) .. M104L-N

In the event of the failure of any part of this equipment, contact your Snap-On Tools representative for replacement parts and service. When ordering parts from Snap-On Tools Corporation, order numbers should be preceded by "**CKS**".

## WARNING

**DO NOT** lift the unit when a gas cylinder is installed or attached.

**DO NOT** weld on any item that has a common electrical ground.

**DO NOT** operate the unit with the side panels removed. Overheating will occur.

**DO NOT** weld upon the case of the welding machine.

**ONLY** a qualified electrician should perform work inside the welding machine.

**ALWAYS** wear protective clothing, leather gloves and a full cover welding hood while welding.

**DO NOT** weld in a closed in area. Proper ventilation is a necessity, or a fresh air supplied hood should be worn.

**WHEN** welding near combustibles, a helper or "watcher" should stand by with a fire extinguisher or other fire protective device.

**NEVER** weld on a closed vessel or one that has contained combustibles.

**IF IN DOUBT - DON'T DO IT!**

**BE SAFE - DON'T BE SORRY!**



## TROUBLE SHOOTING (SYMBOL\*)

FOR TECH. SERVICE, CALL TOLL-FREE 1-800-232-9353

The Trouble Shooting Chart is a guide in identifying and correcting possible troubles which may occur when operating this equipment.

FAULT	POSSIBLE CAUSE	REMEDY
<b>EQUIPMENT MALFUNCTION</b>		
No main power, fan does not operate, "on" indicator light is off.	MM140SL switch is "OFF". (CB1) Wall breaker is "tripped". "Open" circuit breaker on MM140SL. (CB1) Loose or broken connection in power input circuit.	Turn switch "on". Reset wall breaker. Reset or replace breaker. Tighten or repair connection.
Main power on, torch trigger activated, no response.	MIG torch unplugged. Faulty trigger switch. (S1) Fault in torch cable.  Loose or broken connection on wiring harness. (PLG2) Wire feed motor unplugged. (RC5) Faulty control transformer. (T2) Loose spot timer circuit board. (PC2) Defective spot timer circuit board. (CR2)(PC2)	Plug in MIG torch. Replace micro switch. Check torch cable for continuity. Check or repair connections. Plug in motor.  Check for 28VAC output.  Install properly.  Replace board.
Main power on, torch trigger activated, no wire feed but contactor operates & gas flows.	Pressure roll arm unlatched. "Slippage" at drive rolls.  Wire path restricted.  5 amp mini breaker is tripped. (CB2) Wire feed circuit board needs calibrated.  Defective wire feed circuit board. (PC1) Faulty wire feed motor or connection. (M)  Faulty motor relay. (CR1)  Loose or broken connection.	Latch arm & add tension. Increase drive roll tension. See page 8. Clean path or replace torch liner. Reset or replace breaker. Calibrate wire feed circuit board. See page 19. Replace circuit board.  Repair or replace faulty item. Check motor on a 12VDC battery. Sand points or replace relay. Tighten or repair connection.

(continued on following page)

(SYMBOL\*) - USE THIS IDENTIFIER, ALONG WITH THE SCHEMATIC DIAGRAM FOUND IN THE SERVICE MANUAL, FOR TROUBLE-SHOOTING PURPOSES.

**TROUBLE SHOOTING (Cont.)** (SYMBOL\*)  
FOR TECH. SERVICE, CALL 1-800-232-9353

FAULT	POSSIBLE CAUSE	REMEDY
<b>EQUIPMENT MALFUNCTION (Cont.)</b>		
Main power on, torch trigger activated, no welding current, but gas flows & wire feeds.	Loose torch thumb screw. Broken or loose connection.  Unplugged or faulty power contactor switch. (W) #1 Transformer wire off. (W) "Opened" thermal switch. (TP1) Faulty diodes. (D1-D2)	Tighten thumb screw. Check cables for continuity. Repair or tighten connections. Plug in or replace switch. Reattach wire.  Allow unit to cool, then retry. Check diodes. See page 18.
Main power on, torch trigger activated, no gas flow, but contactor operates & wire feeds.	No shielding gas - tank empty. Loose or broken connections. Faulty Gas solenoid valve. (GS) Clogged gas flow path. Loose spot timer circuit board. (PC2) Defective spot timer circuit board. (CR2)(PC2)	Replace tank.  Tighten or repair connections. Repair or replace valve. Locate & clean clog. Install properly.  Replace board.
<b>FAULTY WELDS</b>		
"Jerky" or "slipping" wire feed.	Worn , kinked or dirty torch liner. Wire spool turns too hard. Worn double v-groove drive roll. Weak pressure roll spring. Worn or dirty contact tip. Worn inlet guide(s). Sticking pressure roll. Feed roll tension incorrect.	Clean or replace liner. Lubricate spool hub with a dry lubricant. Replace drive roll.  Replace spring. Replace contact tip. Clean or replace guides. Replace pressure roll. Adjust feed roll tension. See page 8.

**TROUBLE SHOOTING (Cont.)** (SYMBOL\*)  
 FOR TECH. SERVICE, CALL TOLL-FREE 1-800-232-9353

FAULT	POSSIBLE CAUSE	REMEDY
<b>FAULTY WELDS (Cont.)</b>		
"Birdnesting" (Wire wrapping around drive rolls)	Excessive feed roll tension.  Poor alignment.  Oversize contact tip.	Reduce tension. See page 8. Make sure wire is properly aligned across roller. Replace contact tip with correct size.
"Cold" weld puddle.	Incorrect machine settings.  Incorrect shielding gas. Excessive wire stick-out.  Poor connections.  Faulty diode. <i>(D1-D2)</i>	Increase heat & wire speed. Replace with proper gas. Hold torch closer to work. Check and tighten all connections. Test diodes, replace faulty diode(s). See page 18.
Heavy spatter.	Incorrect machine settings.  Incorrect shielding gas. Excessive wire stick-out.	Increase heat, decrease wire feed speed. Replace with proper gas. Hold torch closer to work.
Porous welds.	No shielding gas. Not enough gas flow.  Contaminated wire. Faulty gas solenoid. <i>(GS)</i> Incorrect electrode wire. Contaminated base material.	Turn on gas. Check hoses for leaks, make sure cylinder is not empty. Increase flow rate. Change wire. Replace solenoid.  Use correct wire. Clean or etch base material.

(SYMBOL\*) - USE THIS IDENTIFIER, ALONG WITH THE SCHEMATIC DIAGRAM FOUND IN THE SERVICE MANUAL, FOR TROUBLE-SHOOTING PURPOSES.

## TESTING AND REPLACING DIODES

Silicon diodes have proven to be highly reliable. However, weld spatter build-up in the torch can short out and cause diode overload and consequent failure. The following information is provided as a guide should a failure be suspected.

Silicon diodes exhibit two main fault conditions:

1. "Open Circuit" - causes a reduction in welder output.
2. "Short Circuit" - causes the circuit breaker to trip.

If a fault is suspected, the diode may be tested as follows:

1. Remove the top connection of each diode to be tested.
2. Using a Volt-Ohm Meter set on RX1K, check for continuity through the diode in both directions. If there is no continuity in either direction, the diode is in "open circuit" condition and must be replaced. If there is continuity in both directions, the diode is in "short circuit" condition and must be replaced. If there is continuity in one direction only, the diode is functioning properly.

3. If all the diodes check out satisfactorily with the Volt-Ohm Meter, a load check must be made. This is easily accomplished using a twelve volt battery and a twelve volt light bulb connected as shown. Again test for electrical current flow in both directions. The bulb should light in one (1) direction only - not both.

### CAUTION

**NEVER** use a "megger" or a high voltage device to test a diode.

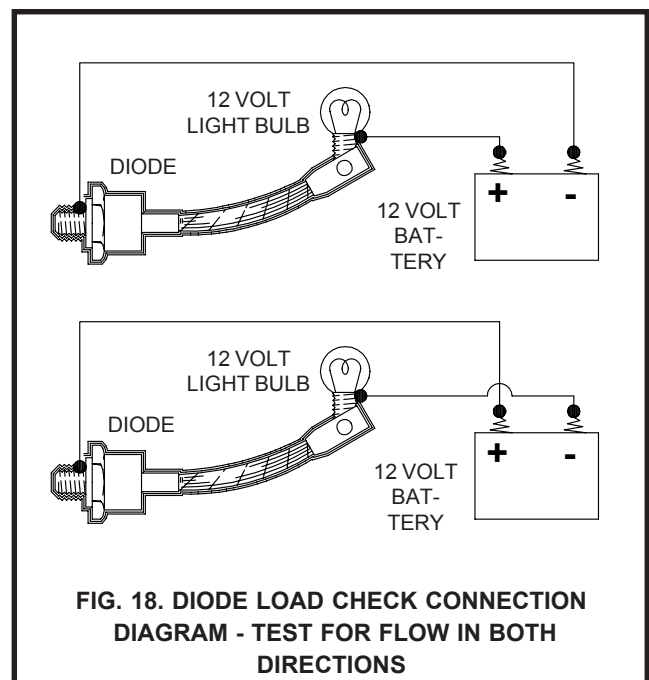

4. When replacing diodes, it is very important that a heat conductive compound (Radio Shack #276-1372) be used where the diode makes contact with the aluminum heat sink. Do not grease the threads on the diode.

## WIRE FEED CALIBRATION

Due to **INPUT LINE VOLTAGE** variations supplied to the welding machine. The **WIRE FEED SPEED** should be checked for proper operation.

### TO CHECK

1. Remove any tension on the drive roll.
2. Turn the wire speed dial (on the front of the machine) to "0".
3. Activate the torch trigger.
4. The bottom drive roll should rotate very slowly(non-jerky).
5. If this proves to be true, no adjustment is required.

### IF ADJUSTMENT IS REQUIRED

1. Remove the top cover assembly from the base unit.
2. Locate the printed circuit boards.
3. Referring to Figure 19, locate the trim resistor, this is located in the upper right hand corner of the wire feed PC board.
4. Turn the wire speed dial (on the front of the machine) to "0".
5. Remove any tension on the drive roll.
6. Activate the torch trigger.

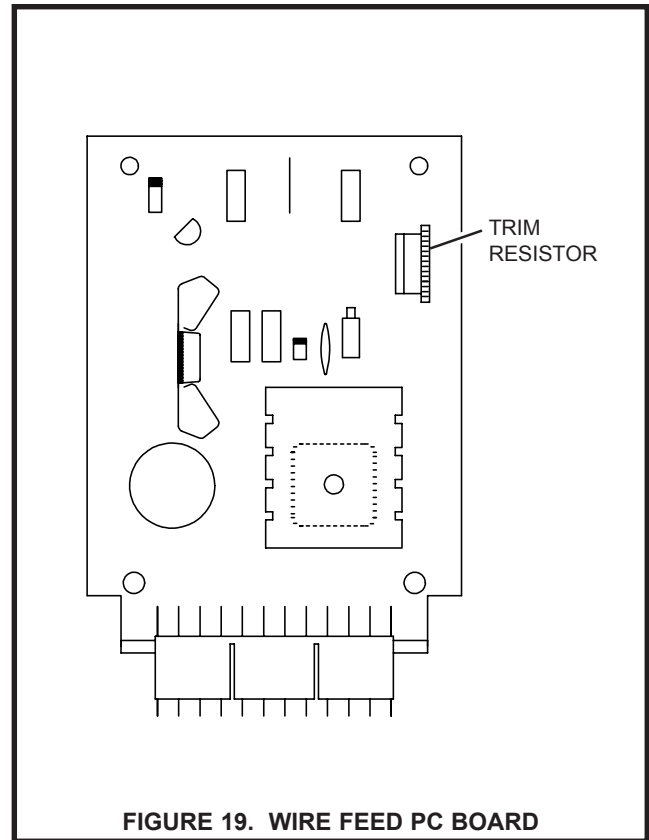

**FIGURE 19. WIRE FEED PC BOARD**

7. Rotate the trim resistor, back and forth, until the bottom drive roll moves.
8. Calibrate so the bottom drive roll rotates very slowly (non-jerky).
9. If calibrated correctly the wire speed dial (on the front of the machine) should affect the speed of the drive roll from "0" thru "10".
10. Adjustment is now complete!

## CONNECTING THE FLEXTIG

### CHANGING FROM STANDARD MIG OPERATION TO FLEXTIG OPERATION

1. Unplug the feeder control cable plug from the control receptacle (OUTPUT) on the welder.
2. Unplug the feeder gas-current cable/power plug and the work cable from the welders front panel.
3. Plug the **FLEXTIG** torch power cable into the negative (-) weld terminal and plug the work cable into the positive (+) weld terminal. This provides straight polarity current as required for **TIG** welding.
4. Plug the **FLEXTIG** torch switch cord into the welder control receptacle (OUTPUT).
5. Attach the **FLEXTIG** torch gas hose directly to the gas regulator/flowmeter and adjust the flow to 20 C.F.H.

#### NOTE

Pure Argon is the shielding gas to be used for TIG welding.

6. Follow the operating instructions in the **FLEXTIG** manual (Form WC5229).
7. To change back to standard **MIG** operation, reverse the procedure.

## CONNECTING THE MHG5-B SPOOL GUN

### CHANGING FROM STANDARD MIG OPERATION TO SPOOL GUN OPERATION

1. Unplug the feeder control cable plug from the control receptacle (OUTPUT) of the welder.
2. Plug the **MHG5-B** spool gun control cable plug into the welder control receptacle (OUTPUT).
3. Remove the feeder gas-current cable/power plug from the welders positive (+) weld terminal.
4. Plug the **MHG5-B** gun cable fitting into the welder positive (+) weld terminal.

#### NOTE

Make sure the welder primary gas hose and regulator/flowmeter are connected to a cylinder of the proper shielding gas - 100% Argon for aluminum and 98% Argon + 2% O<sub>2</sub> for stainless steel and 75% Argon + 25% CO<sub>2</sub> for steel welding.

5. Follow the operating instructions in the **MHG5-B** manual (Form WC5268).
6. To change back to standard **MIG** operation, reverse the procedure.

## M.I.G. TORCH LINER INSTALLATION (steel only)

The MIG torch liner provided with the **MM140SL** is designed for wire diameters from .020 thru .030. If larger wire diameters are to be fed and or there is a problem (i.e. clog, kink, etc.), a liner change is required.

Following is a step by step guide to aid in liner removal and installation.

### NOTE

When removing the welding wire from the MIG torch, care should be taken to avoid the wire from uncoiling from the wire spool.

### REMOVING OLD LINER

1. Remove torch assembly from the welding machine.
2. Place torch assembly on a flat surface, making sure torch is laying straight as possible.
3. Remove nozzle, bushing insulator, contact tip and gas diffuser from the front end of the torch assembly.
4. Loosen set screw located on the connector end of the torch assembly (see FIG. 21).
5. Grip the liner and gas seal firmly, then pull. The liner should easily slide from torch assembly.

### INSTALLING NEW LINER

1. Remove the new liner from the package.
2. Uncoil liner and lay the liner parallel next to the MIG torch assembly.
3. Adjust the liner stickout length to 3/4" as shown in FIG. 20.

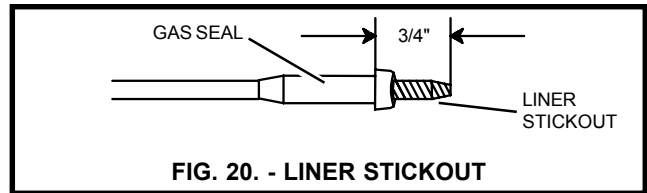

FIG. 20. - LINER STICKOUT

4. Install the new liner into the MIG torch assembly, until gas seal seats flush with the connector plug.
5. Tighten set screw. (Do not over-tighten), refer to FIG. 21.

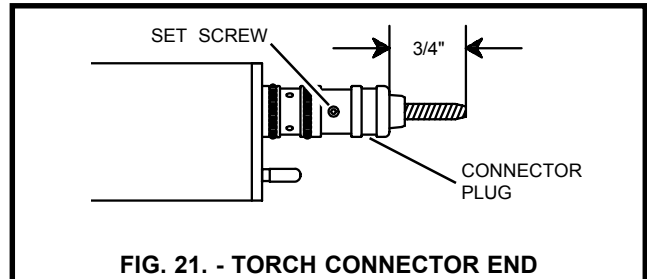

FIG. 21. - TORCH CONNECTOR END

6. Following the diagram in FIG. 22, measure out 1 1/4" + from the neck assembly and cut off the protruding liner.
7. Deburr the cutoff end of the liner to insure unobstructed wire feed.

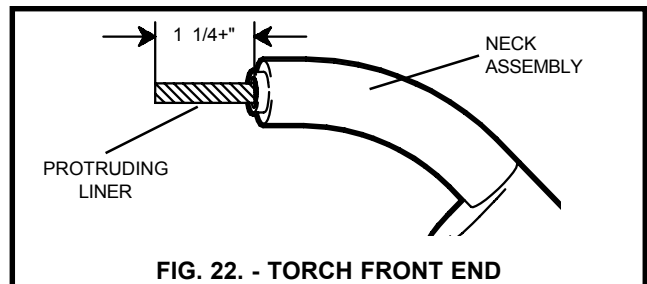



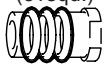

FIG. 22. - TORCH FRONT END

8. Install the gas diffuser and contact tip of proper wire size, tighten with a wrench.
9. Install the bushing insulator onto the gas diffuser. Spray the "O" rings with anti-spatter compound for lubrication.
10. Install the TWIST-ON adjustable nozzle and twist the nozzle during the installation. Turn to Page 7 for correct nozzle adjustment.

# CONSUMABLE PARTS BREAKDOWN - 15 SERIES M.I.G. TORCH







## TG STYLE FRONT END - STANDARD

WIRE SIZE	CONTACT TIP	GAS DIFFUSER	NOZZLE	INSULATOR	INSULATOR O-RING
.020 - .025 inch .030 inch .035 inch .040 - .047 inch	M3-T25 M3-T30 M3-T35 M3-T45  (1-7/16" length)	M3T-D 	M3T-N50 (1/2" I.D.) 	M3T-B (includes o-rings) 	M3T-BR (3 reqd.) 

### SPECIAL APPLICATION PARTS FOR TG STYLE FRONT END

SHORT CONTACT TIP (1-1/4" length) - For Spray Arc Welding		LARGER ORIFICE NOZZLE	SPOT WELDING NOZZLES		
WIRE SIZE	PART NUMBER		STYLE	Standard Nozzle PART NUMBER	Low Amp Nozzle PART NUMBER
.020 - .025 inch	M3-ST25	Straight Nozzle (3/4" I.D.) M3T-N75	Flat Spot	M3T-NS1	M3T-NLAS1
.030 inch	M3-ST30		Inside Corner	M3T-NS2	M3T-NLAS2
.035 inch	M3-ST35		Outside Corner	M3T-NS3	M3T-NLAS3
.040 - .047 inch	M3-ST45		Irregular (grind to shape)	M3T-NS4	M3T-NLAS4



## SG STYLE FRONT END - OPTIONAL

WIRE SIZE	CONTACT TIP	GAS DIFFUSER	NOZZLE ASSEMBLY	CUP	NOZZLE BODY	INS. BUSHING
.020 - .025 inch .030 inch .035 inch .040 - .047 inch	M3-T25 M3-T30 M3-T35 M3-T45  (1-7/16" length)	M3-D 	M3-NA50 	M3-C50 (1/2" I.D.) 	M3-NB 	M3-B 

### SPECIAL APPLICATION PARTS FOR SG STYLE FRONT END

SHORT CONTACT TIP (1-1/4" length) - For Spray Arc Welding		LARGER ORIFICE CUP	EXTRA LENGTH FRONT END		SPOT WELDING FRONT END		
WIRE SIZE	PART NUMBER		1/2" Longer PART NUMBER	1" Longer PART NUMBER	PART NUMBER		
.020 - .025 inch	M3-ST25	Flared Cup (5/8" I.D.) M3-C62	CUP (1/2" I.D.) CONTACT TIP	M3-C50L	M3-C50XL	INS. BUSHING	M3H-B
.030 inch	M3-ST30					NOZZLE NUT	M3H-NN
.035 inch	M3-ST35					SPOT NOZZLE	
.040 - .047 inch	M3-ST45					Flat Spot	M3H-NS1
			.020 - .025 inch	M5-T25	M5-LT25	Inside Corner	M3H-NS2
			.030 inch	M5-T30	M5-LT30	Outside Corner	M3H-NS3
			.035 inch	M5-T35	M5-LT35	Irregular	M3H-NS4
			.040 - .047 inch	M5-T45	M5-LT45		

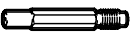
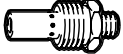
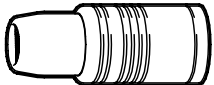
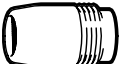
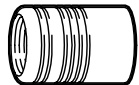
## XG STYLE FRONT END - OPTIONAL - RECOMMENDED FOR ALUMINUM WELDING

WIRE SIZE	CONTACT TIP	GAS DIFFUSER	NOZZLE ASSEMBLY	CUP	NOZZLE BODY	INS. BUSHING
.035 inch .040 - .047 inch	M5-T35 M5-T45  (1-15/16" length)	M35-D 	M35-NA62 	M5-C62 (5/8" I.D.) 	M5-NB 	M5-B 

### SPECIAL APPLICATION PARTS FOR 3-5G STYLE FRONT END

LARGER ORIFICE CUP: Straight Cup (3/4" I.D.) ..... M5-C75

### SPECIAL FRONT END FOR GASLESS WIRES - OPTIONAL

INSULATED CONTACT TIP (Tip screw directly into torch neck - no gas diffuser is required) (1-15/16" length)

WIRE SIZE	PART NUMBER
.040 - .047 inch	M5HGL-045

### LINERS & LINER SEALS

#### FOR STEEL WELDING

WIRE SIZE	TORCH LENGTH	ORDER NUMBER	
		LINER W/SEAL	SEAL ONLY
.020-.030 inch	10 feet	M103L-B	M3LS-B (Blue)
.035-.045 inch	10 feet	M104L-N	M4LS-N (Natural)
	12 feet	M124L-N	

#### FOR ALUMINUM WELDING

WIRE SIZE	TORCH LENGTH	ORDER NUMBER		
		LINER ONLY	SEAL ONLY	HEATSHIELD ONLY
.035 inch	10 feet	M103AL	M3-6ALS	M3-THS
3/64 inch	10 feet	M104AL	M3-6ALS	M3-THS



# PARTS BREAKDOWN - 15 SERIES MIG TORCH (Cont.)

## PART NO. DESCRIPTION (SYMBOL)

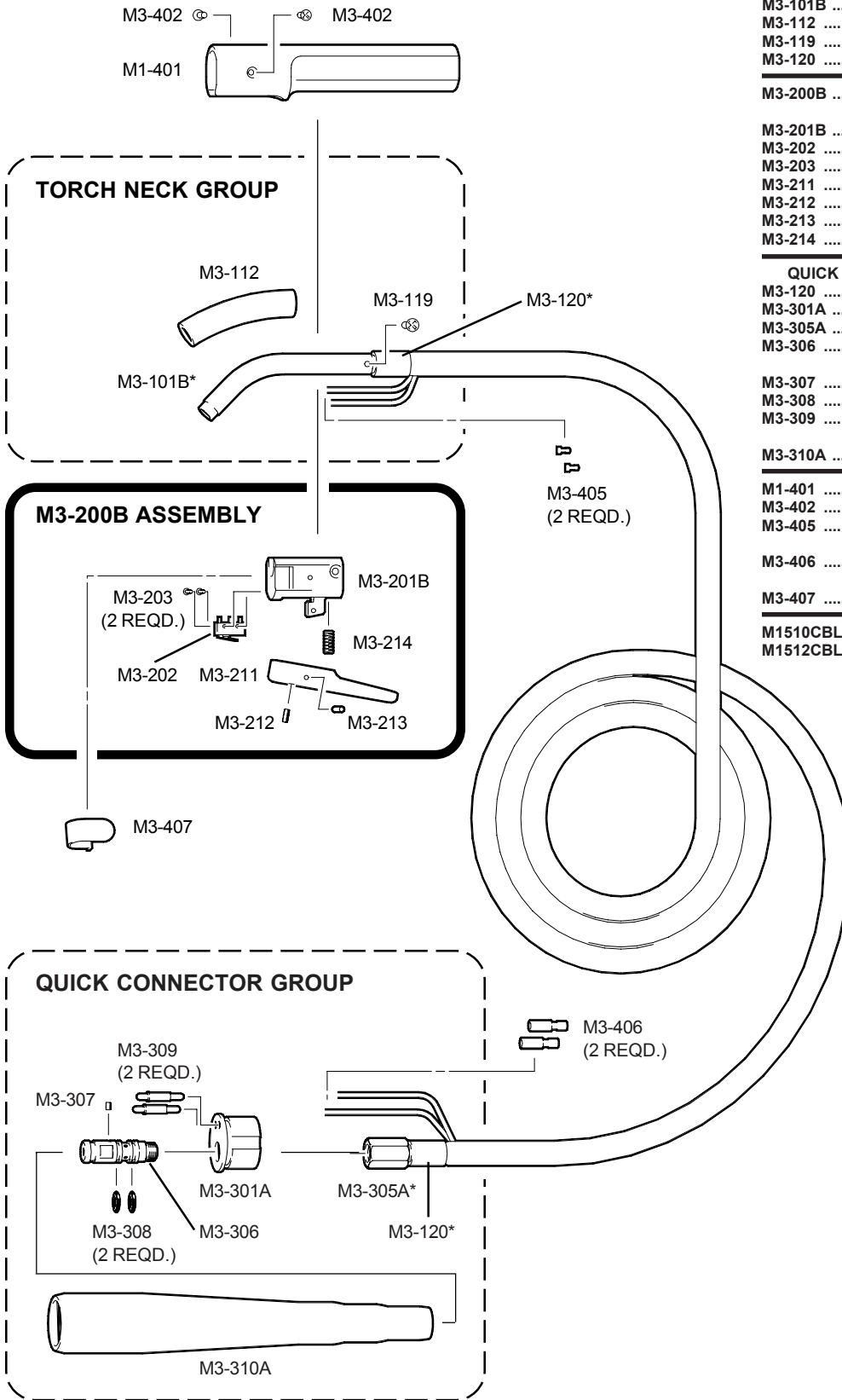

TORCH NECK GROUP	
M3-101B	..... TORCH NECK *
M3-112	..... NECK INSULATOR
M3-119	..... LOCK SCREW - SWITCH HOUSING
M3-120	..... FERRULE *
<hr/>	
M3-200B ..... SWITCH ASSEMBLY	
CONSISTING OF:	
M3-201B	..... SWITCH HOUSING
M3-202	..... SWITCH (S1)
M3-203	..... SWITCH SCREW (2 REQUIRED)
M3-211	..... TRIGGER - WITH ADJUSTING SCREW
M3-212	..... TRIGGER ADJUSTING SCREW (ONLY)
M3-213	..... TRIGGER PIN
M3-214	..... TRIGGER SPRING
<hr/>	
QUICK CONNECTOR GROUP	
M3-120	..... FERRULE *
M3-301A	..... CONNECTOR HOUSING
M3-305A	..... CONNECTOR STEM *
M3-306	..... CONNECTOR PLUG
- WITH SETSCREW & O-RINGS	
M3-307	..... SETSCREW (ONLY)
M3-308	..... O-RING (ONLY) (2 REQUIRED)
M3-309	..... TERMINAL - CONNECTOR CONTACT
(2 REQUIRED)	
M3-310A	..... BOOT / CABLE SUPPORT
<hr/>	
M1-401	..... HANDLE
M3-402	..... HANDLE SCREW (2 REQUIRED)
M3-405	..... TERMINAL - TORCH END
(2 REQUIRED)	
M3-406	..... TERMINAL - CONNECTOR END
(2 REQUIRED)	
M3-407	..... HANGING BRACKET
<hr/>	
M1510CBL...	10 FOOT CABLE *
M1512CBL...	12 FOOT CABLE *

M1510CBL\*  
M1512CBL\*

### NOTES:

\* BECAUSE SPECIAL TOOLS AND PROCEDURES ARE REQUIRED TO PROPERLY INSTALL THE CABLE ON THE TORCH NECK AND THE CONNECTOR STEM, ITEMS WITH THE ASTERICK ARE AVAILABLE FACTORY INSTALLED ONLY.

**TORCH REBUILD PROGRAM**  
15 SERIES TORCHES CAN BE REBUILT BY THE FACTORY FOR A NOMINAL LABOR + PARTS CHARGE.

# OPTIONS

## FLEXTIG

### TIG WELD WITH YOUR SNAP-ON TOOLS MUSCLE MIG SYSTEM (MM140SL, MM250SL)

The TIG Welding Process is used to produce the highest quality, porosity-free welds. The FLEXTIG adds TIG Welding capabilities to your Snap-on Tools MIG Welder.

The FLEXTIG is designed for Tungsten-Inert Gas (TIG) welding with Direct Current, Straight Polarity (DCSP) on steel, stainless steel, chrome-moly, copper or cast iron (18 Ga. minimum plate thickness).

#### **THE FLEXTIG WILL NOT WELD ALUMINUM.**

The FLEXTIG consists of a 200 amp, gas cooled torch with built-in gas control valve and remote on-off switch, 12-1/2 or 25 foot cable assembly and accessories required for putting the unit in service.

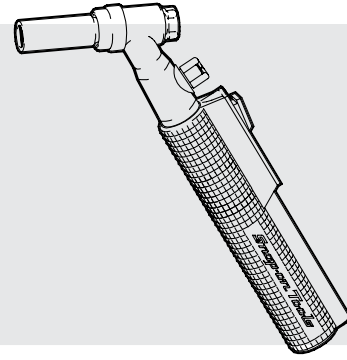

#### SPECIFICATIONS

Part Number .....	FLEXTIG 12 (12-1/2' cable) FLEXTIG 25 (25' cable)
Torch Rating .....	200 Amps, DCSP
Duty Cycle .....	100% (reduce duty cycle when operating over 200 amps.)
Cooling Method .....	Gas(100% ARGON)
Shielding Gas	
Control Method .....	Gas Valve on Torch
Welding Current	
On-Off Control .....	Locking Switch on Torch

#### CONTENTS OF FLEXTIG

1 each	TIG Torch with built-in valve
1 each	Locking Electric Switch with cord & plug (installed on torch)
1 each	12-1/2 foot Power Cable with Connector (installed on torch)
1 each	15 foot Gas Hose with fitting (installed on torch)
3 each	3C116 Collet - for 1/16" tungsten
3 each	3C332 Collet - for 3/32" tungsten
2 each	3CB116 Collet Body - for 1/16" tungsten
2 each	3CB332 Collet Body - for 3/32" tungsten
2 each	3C6 Gas Cup - 3/8" orifice
6 each	3C7 Gas Cup - 7/16" orifice
2 each	3C8 Gas Cup - 1/2" orifice
1 each	300L Long Backcap
3 each	1/16" X 3" Tungsten Electrode
3 each	3/32" X 3" Tungsten Electrode

## MHG5-B

### ONE POUND SPOOL GUN FOR ALUMINUM MIG WELDING WITH SNAP-ON TOOLS MUSCLE MIG SYSTEMS (MM140SL, MM250SL)

The MHG5-B (Motorized Hand Gun System) is a compact, light-in-weight, easy to operate MIG welding system designed for aluminum welding. It will feed .023" Thru 3/64" diameter wire from 4 inch spools. The standard equipment cable is 25 feet in length. 35 foot and 50 foot cables are optional. The wire speed control knob is built into the gun handle.

With the following options, the MHG5-B can also be used to weld steel or stainless steel (.030"-.035" diameter wire size).

- SN-2160K** Knurled Drive Roll for .030 - .035" steel wire
- M5-T30** Contact tip - for .030" steel wire
- or M5-T35** Contact tip - for .035" steel wire

#### SPECIFICATIONS

Part Number .....	MHG5-B
Gun Rating .....	200 Amps @ 100% duty cycle 250 Amps @ 60% duty cycle
Wire Feed Speed Range ...	50 to 650 inches per minute
Cooling Method .....	Air (gas)

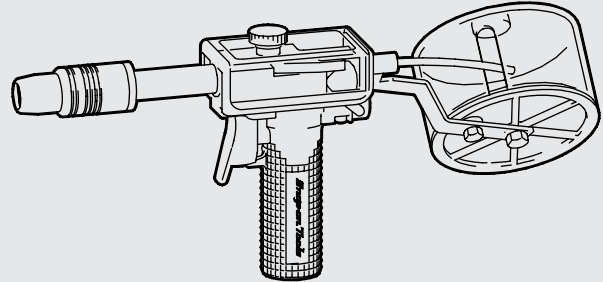

#### MHG5-B SYSTEM COMPONENTS

1 each	MHG-5 Spool Gun (only)
1 each	HGC9-25 Hand Gun Cable Assembly with fittings - 25 feet length
7 each	MG-TXX Contact Tip(1 installed in gun) 2 - .030 (MG-T30) 3 - .035 (MG-T35) 2 - 3/64 (MG-T364)
1 each	M35-NA62 Nozzle Assembly (installed on gun)
1 each	M35-D Gas Diffuser (installed on gun)

## PARAMETER CHARTS



### Guide For Setting Welder - Adjust For Best Results GAS METAL ARC (MIG) PROCESS - DCEP (REVERSE POLARITY)

Note: Settings are approximate and may vary. Adjust for best results.

MATERIAL	SHIELDING GAS		WELDING WIRE		THICKNESS	MIG VOLTAGE	WIRE SPEED				
	TYPE	FLOW	TYPE	SIZE							
CARBON STEEL	75% ARGON 25% CO2	25 CFH (Min.)	ER70S-6	.023"/ .025"	24 Ga.(.024")	1	2 1/2				
					22 Ga.(.030")	2	3				
					20 Ga.(.036")	3	4				
					18 Ga.(.048")	4	4 1/2				
					16 Ga.(.060")	5	5 1/2				
					14 Ga.(.075")	6	7				
					12 Ga.(.105")	7	8				
					1/8"	7	8 1/2				
				.030"	24 Ga.(.024")	1	2				
					22 Ga.(.030")	1	2 1/2				
					20 Ga.(.036")	2	3				
					18 Ga.(.048")	3	4				
					16 Ga.(.060")	4	5				
					14 Ga.(.075")	5	5 1/2				
					12 Ga.(.105")	6	6				
					1/8"	7	6 1/2				
				.035"	3/16"	8	7				
					1/4"	8	8				
					20 Ga.(.036")	1	2 1/2				
					18 Ga.(.048")	2	3				
					16 Ga.(.060")	3	4				
					14 Ga.(.075")	4	4				
					12 Ga.(.105")	5	5				
					1/8"	6	5				
					3/16"	7	5 1/2				
					1/4"	8	6				
					5/16***	8	6				
					3/8***	8	6				
				**Multiple Passes							

#### TIG WELDING PARAMETERS

VOLTAGE SETTING	OUTPUT AMPERAGE	MATERIAL THICKNESS
TIG 1	50 AMPS	18 GA.(.048")
" 2	90 AMPS	14 GA.(.075")
" 3	105 AMPS	1/8" (.125")
" 4	150 AMPS	3/16" (.188")

#### SPOT TIME PARAMETERS

WIRE SIZE	MATERIAL THICKNESS	VOLTAGE SETTING	WIRE FEED	SPOT TIME
ER70S-6	24 GA.(.024")	MIG 5	4	1
.030" DIA.	22 GA.(.030")	" 6	5	1
	18 GA.(.048")	" 7	6	1 1/2
	16 GA.(.060")	" 8	8	1 1/2

Note: Settings are approximate and may vary. Adjust for best results.

#### PROPER DRIVE ROLL ORIENTATION

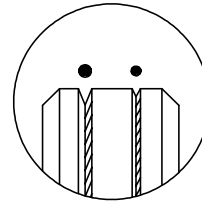

USE LARGE GROOVE FOR .045" DIA. WIRE

USE SMALL GROOVE FOR .023" - .035" DIA. WIRE

Position adjusting collar to align drive roll groove with centerline of wire guide tube. Then secure drive roll with the washer and the nut provided.

