

MM250SL

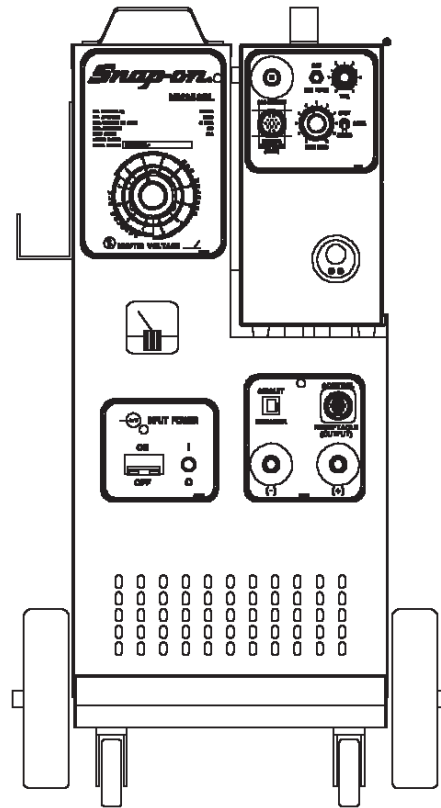

SERVICE MANUAL

FOR
SERIAL NUMBERS MM250SL-2000 AND LATER

CONTENTS

VIEW	DESCRIPTION	PAGE
FIGURE 1	SCHEMATIC DIAGRAM	3
FIGURE 1A	SCHEMATIC, WIRE FEED CIRCUIT BOARD	4
FIGURE 1B	SCHEMATIC, SPOT TIME CIRCUIT BOARD	4
FIGURE 2	WIRING DIAGRAM, CONTROL CABLE ASSEMBLY	5
FIGURE A	FRONT ASSEMBLY	6
.....	PARTS LIST	7
FIGURE B	LEFT SIDE VIEW & INTERNAL COMPONENTS	8
.....	PARTS LIST	9
FIGURE B1	PRINTED CIRCUIT BOARD (SN-774U)	10
.....	PARTS LIST	11
FIGURE C	FRONT VIEW-REMOTE FEED UNIT	12
.....	PARTS LIST	13
FIGURE D	RIGHT SIDE VIEW & INTERNAL COMPONENTS	14
.....	REMOTE FEED UNIT	
.....	PARTS LIST	15
FIGURE D1	PRINTED CIRCUIT BOARD (SN-529U)	16
.....	PARTS LIST	17
FIGURE D2	WIRE DRIVE ASSEMBLY (SN-138C24M)	18
.....	PARTS LIST	19
FIGURE E	FEEDER CABLE ASSEMBLY (FCA-15)	20
.....	PARTS LIST	20

FIGURE 1 - SCHEMATIC DIAGRAM

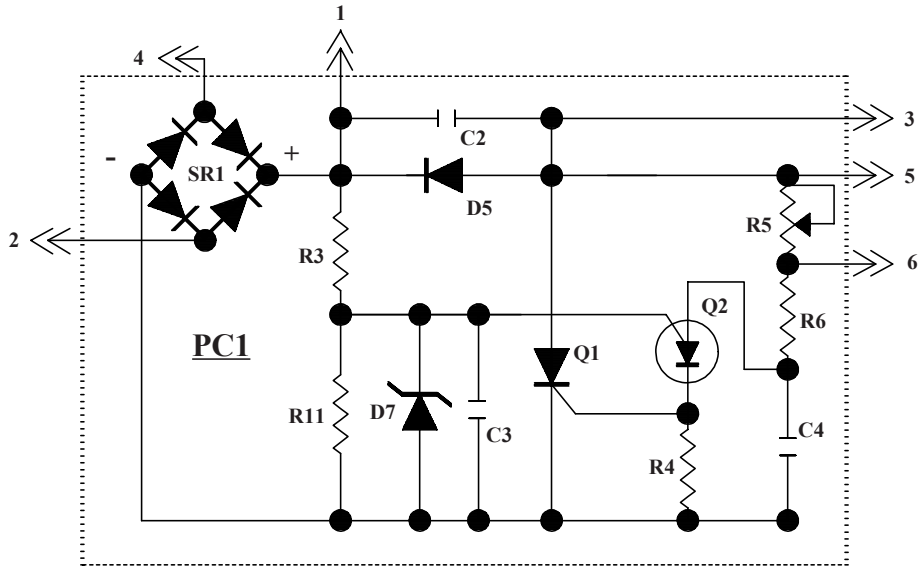

FIGURE 1A - SCHEMATIC, WIRE FEED CIRCUIT BOARD

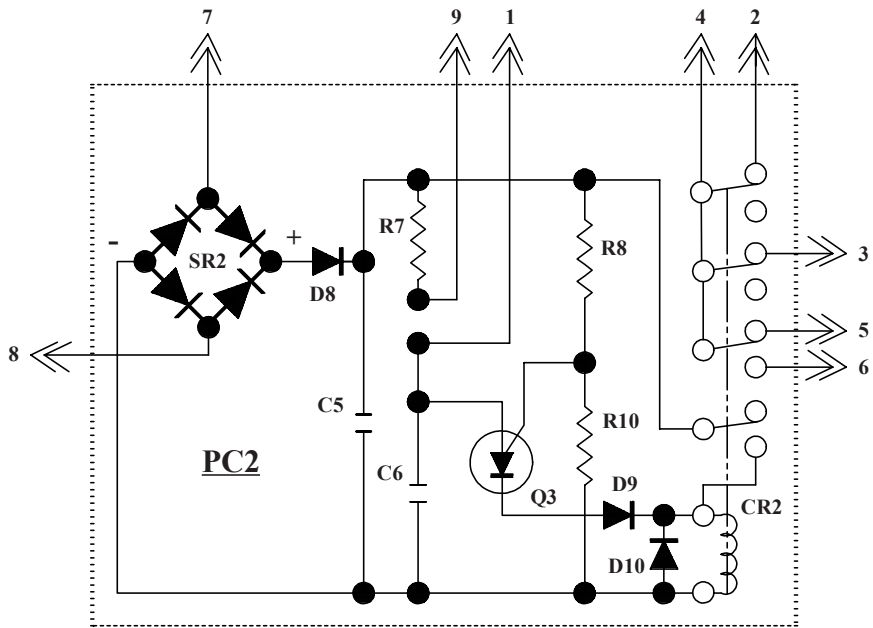

FIGURE 1B - SCHEMATIC, SPOT TIME CIRCUIT BOARD

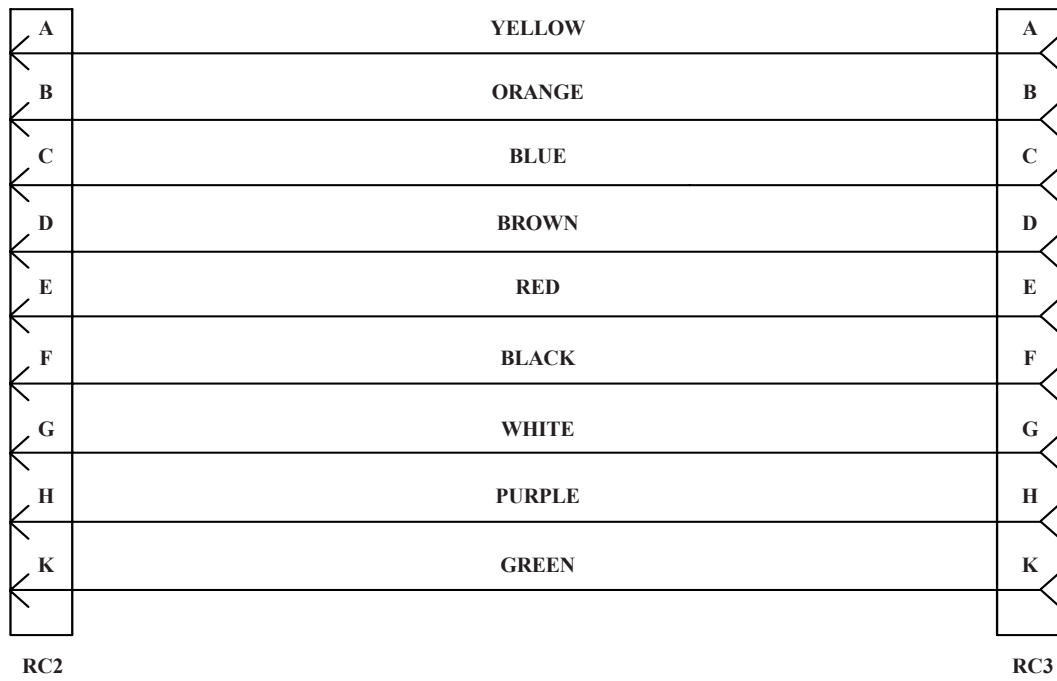

FIGURE 2 - WIRING DIAGRAM, CONTROL CABLE ASSEMBLY

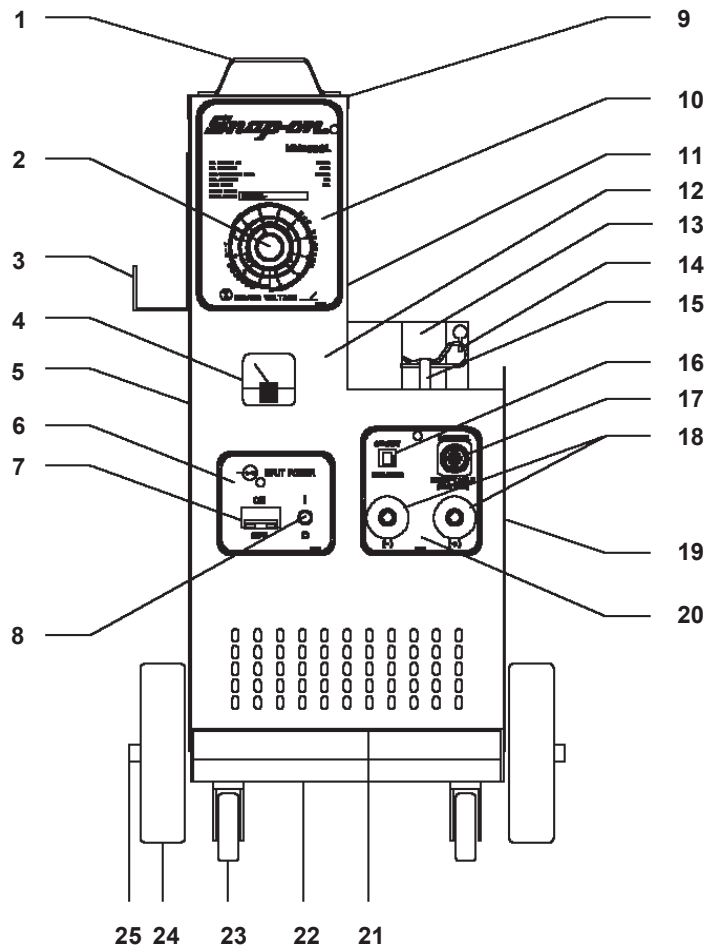

FIGURE A - FRONT ASSEMBLY

FIGURE A

ITEM NO.	DIA. MKGS.	PART NO.	DESCRIPTION	QTY.
1		SN-180A	HANDLE	1
2		SN-330A	KNOB, HEAT	1
3		SN-319	CABLE HANGER	2
4	V	SN-115	VOLTMETER (ROUND CORNERS)	1
		SN-115A	VOLTMETER (SQUARE CORNERS) (SERIAL# MM250SL-6020 AND LATER)	1
		SN-115L	LENS, VOLTMETER (ROUND CORNERS)	1
		SN-115AL	LENS, VOLTMETER (SQUARE CORNERS)	1
5		SN-306M	LEFT SIDE	1
6		SN-1102	LABEL, ON/OFF	1
7	CB1	SN-482	CIRCUIT BREAKER, 35 AMP	1
		SN-955	BREAKER BRACKET	1
8	L	SN-184	INDICATOR LAMP	1
9		SN-5070	COVER, TOP	1
		SN-5070A	COVER, TOP (SERIAL# MM250SL-5475 AND LATER)	1
10		SN-1058	LABEL, CONTROL	1
11		SN-5050	BAFFLE	1
12		SN-5080	FRONT	1
		SN-5080A	FRONT (SERIAL# MM250SL-5475 AND LATER)	1
13		SN-211	BRACKET, CYLINDER	1
14		SN-699H	CLIP, HAIRPIN (SERIAL# MM250SL-2572 AND LATER)	1
15		SN-699A	STOP W/ CLIP HOLE, FEEDER (REPLACES ORIGINAL)	1
16	CB2	SN-519	MINI BREAKER, 5A	1
17	RC1	SN-6191A	RECEPTACLE, CONTROL (OUTPUT)	1
18		SN-146C	WELD CONNECTOR W/GAS HOLE	2
		SN-72	NUT, WELD CONNECTOR	2
		SN-178	GROUND CABLE ASSEMBLY, 15' (NOT SHOWN)	1
		SN-165	CLAMP, GROUND (NOT SHOWN)	1
19		SN-304M	SIDE, RIGHT	1
		SN-1009	LABEL, PRO'S ADVANTAGE	1
20		SN-1103	LABEL, WELD CONNECTOR	1
21		SN-302W	BASE	1
22		SN-213	CASTER BRACKET	2
23		SN-121-3	CASTER, FRONT 3"	2
24		SN-124-8	REAR WHEEL, 8"	2
25		SN-171	AXLE	1
		SN-171C	AXLE CAPS	2
		SN-217W	WASHERS, AXLE	4

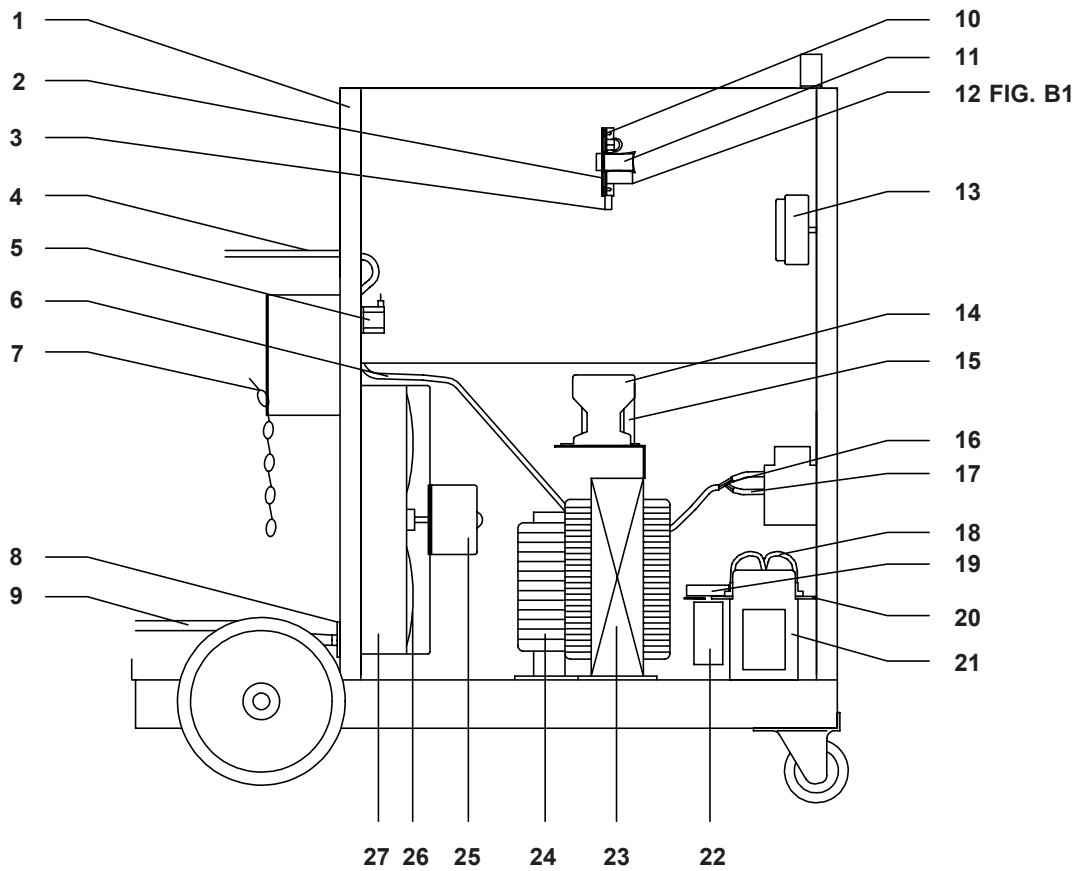

FIGURE B - LEFT SIDE VIEW & INTERNAL COMPONENTS

FIGURE B

ITEM NO.	DIA. MKGS.	PART NO.	DESCRIPTION	QTY.
1		SN-5030	BACK	1
2		SN-421U	BRACKET, CONTROL (U-BOARD).....	1
3		SN-685	TERMINAL HOUSING, HARNESS	1
		SN-685P	PIN, TERMINAL HOUSING	6
4		SN-253A	GAS HOSE, PRIMARY	1
5	GS	SN-126B	SOLENOID ASSEMBLY, 24VAC	1
		2200	GAS FITTING, INLET	1
		2200SN	GAS FITTING, OUTLET	1
6		SN-353C	GAS HOSE	1
7		SN-211C	CYLINDER CHAIN	1
8		SN-220	STRAIN RELIEF	1
		SN-220N	NUT, STRAIN RELIEF	1
9	PLG1	20CP-0	POWER INPUT CABLE, 20'	1
10		SN-601	STAND OFF, NYLON	4
11	CR1	SN-276S	RELAY, 8 PIN	1
		SN-276CL	CLIP, RELAY	1
		SN-236	SOCKET, RELAY 8 PIN	1
12	PC1	SN-774U	WIRE FEED CONTROL BOARD (FIGURE B1)	1
13	S2	SN-163-12	HEAT SWITCH, 12 POSITION	1
14	W	SN-153	CONTACTOR, 24VAC	1
15	T2	SN-287M	CONTROL TRANSFORMER, 230V-28V	1
16		SN-600	FITTING, "Y" HOSE	1
17		SN-353Y	HOSE	2
18	D1,2,3,4	SN-260	DIODE	4
19	R2	SN-162	RESISTOR, 100 OHM 25W	1
20		SN-360	HEAT SINK ASSEMBLY, COMPLETE	1
		SN-360T	HEAT SINK ASSEMBLY, COMPLETE (SERIAL# MM250SL-3949 AND LATER)	1
21		SN-255M	LEG, HEAT SINK	2
22	C1	SN-125S	CAPACITOR, 12,000UF 50V	6
23	T1	SN-286T	TRANSFORMER, POWER	1
	TP1	SN-654	THERMAL SWITCH (N.C.)	1
24	Z	SN-188C	CHOKE	1
25	F	SN-117	FAN MOTOR	1
26		SN-318	BLADE, FAN	1
27		SN-310A	FAN BRACKET W/SHROUD	1

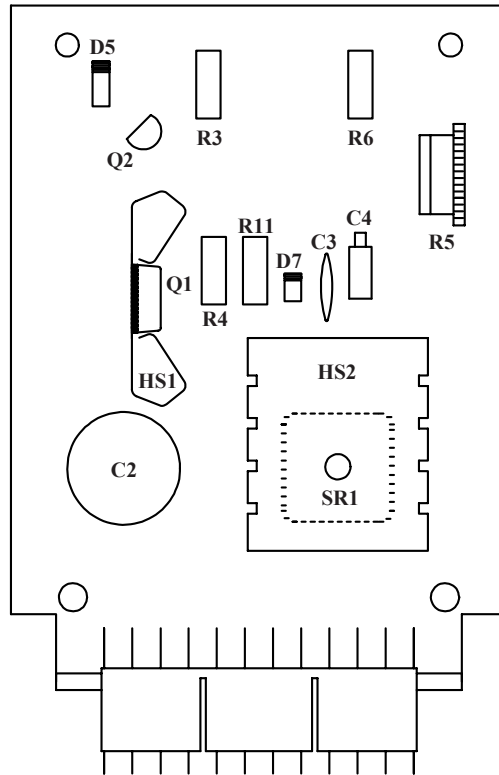

FIGURE B1 - PRINTED CIRCUIT BOARD (SN-774U)

FIGURE B1

ITEM NO.	DIA. MKGS.	PART NO.	DESCRIPTION	QTY.
C2	MI-623		CAPACITOR, 1000uF 50V	1
C3	HG-578		CAPACITOR, .02UF 100V	1
C4	MI-626		CAPACITOR, .68UF 50DC	1
D5	HG-579		DIODE, 2A	1
D7	HG-196		DIODE, ZENER 7.5V	1
HS1	CB-251		HEAT SINK, SCR	1
HS2	CB-250		HEAT SINK, BRIDGE RECTIFIER	1
Q1	HG-194A		SCR, 10A	1
Q2	MI-627		TRANSISTOR, PUT	1
R3,6	CB-043		RESISTOR, 1K OHM 1/2W	2
R4	MI-127		RESISTOR, 100 OHM 1/2W	1
R5	MI-135A		RESISTOR, TRIM 1 MEG OHM	1
R11	MI-159		RESISTOR, 330 OHM 1/2W	1
SR1	CB-048		RECTIFIER, BRIDGE	1

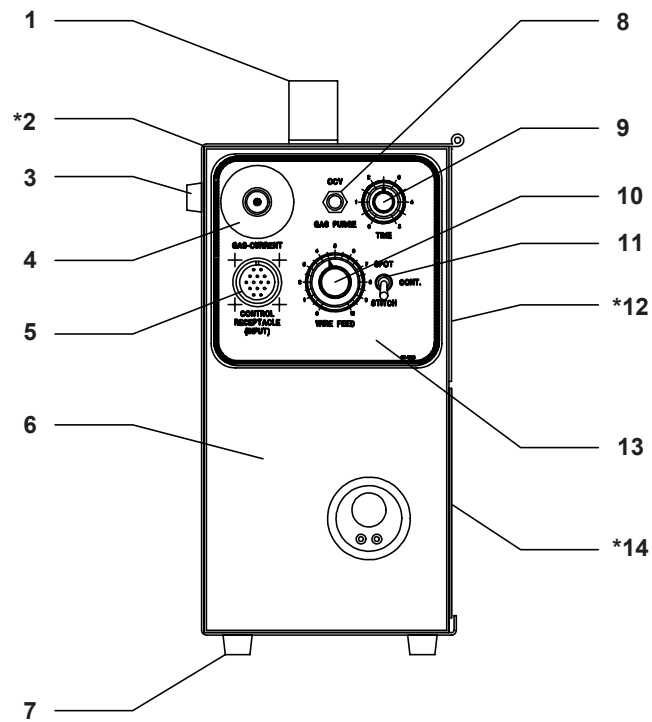

FIGURE C - FRONT VIEW - REMOTE FEED UNIT

FIGURE C

ITEM NO.	DIA. MKGS.	PART NO.	DESCRIPTION	QTY.
1		SN-05	HANDLE	1
*2		SN-5110	CABINET, FEED UNIT (ONLY)	1
		SN-5110A	", (SERIAL# MM250SL-2729 AND LATER)	1
*		SN-5110C	COMPLETE CABINET ASSEMBLY (MUST BE PURCHASED AS A COMPLETE ASSEMBLY)	
3		SN-700	BUMPER PAD, SELF-TAPPING (SERIAL# MM250SL-2572 AND LATER)	2
4		SN-246B	TERMINAL, GAS-CURRENT	1
5	RC4	SN-6190	RECEPTACLE, CONTROL (INPUT)	1
6		SN-5180	FRONT, FEED UNIT	1
7		SN-889F	FEET, RUBBER	4
8	S4	SN-425B	SWITCH, N/O-N/C PURGE	1
9		SN-2520	KNOB, TIMER	1
10		SN-67	KNOB, FEED	1
11	S3	SN-245M	SWITCH, MODE	1
*12		SN-5270U	DOOR, UPPER FEEDER	1
*		SN-5270UP	DOOR PIN (ONLY), UPPER	1
13		SN-1059	LABEL, FEED UNIT CONTROL	1
*14		SN-5270L	DOOR, LOWER FEEDER	1
*		SN-5270LP	DOOR PIN (ONLY), LOWER	1
*		SN-1007	LABEL, MUSCLE MIG	1

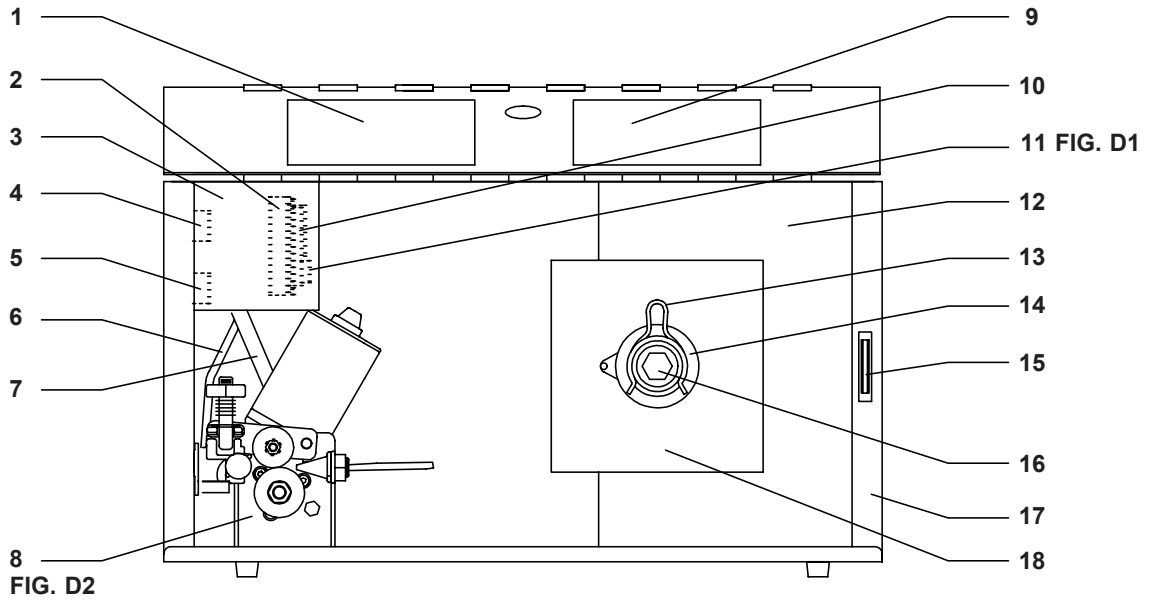

FIGURE D - RIGHT SIDE VIEW & INTERNAL COMPONENTS
REMOTE FEED UNIT

FIGURE D

ITEM NO.	DIA. MKGS.	PART NO.	DESCRIPTION	QTY.
1		LB-1367	LABEL, ACCESS DOOR - LEFT	1
2		SN-6421U	BRACKET, CONTROL (BEHIND COVER)	1
3		SN-6230	DUST COVER	1
4	R9	SN-222	POTENTIOMETER, 35K SPOT TIMER (BEHIND COVER)	1
5	R1	SN-35U	POTENTIOMETER, 75K FEED (BEHIND COVER)	1
6		SN-605A	HOSE, SECONDARY	1
7		SN-609	CABLE, SECONDARY CURRENT	1
8		SN-138C24M	WIRE DRIVE ASSY., COMPLETE (FIGURE D2)	1
9		LB-1368	LABEL, ACCESS DOOR - RIGHT	1
10		SN-685	TERMINAL HOUSING, HARNESS (BEHIND COVER)	1
		SN-685P	PIN, TERMINAL HOUSING (BEHIND COVER)	9
11	PC2	SN-529U	SPOT TIMER BOARD (BEHIND COVER)(FIGURE D1)	1
		SN-601	STAND OFF, NYLON (BEHIND COVER)	4
12		SN-5220	SPOOL BRACKET	1
		SN-5220A	" (SERIAL# MM250SL-2729 AND LATER)	1
13		SN-22	SPOOL CLIP	1
14		SN-122	SPOOL HUB ASSEMBLY	1
		SN-15	SHAFT	1
		SN-16	BUSHING	2
		SN-18	TENSION SPRING	1
		SN-19	WASHER, SPOOL HUB	3
15		SN-606	DOOR CATCH, MAGNETIC	1
16		SN-20B	BOLT, TENSION	1
17		SN-5130	BACK, LARGE FEEDER	1
		SN-5130A	" (SERIAL# MM250SL-2729 AND LATER)	1
18		SN-314I	INSULATOR CARD, SPOOL HUB	1

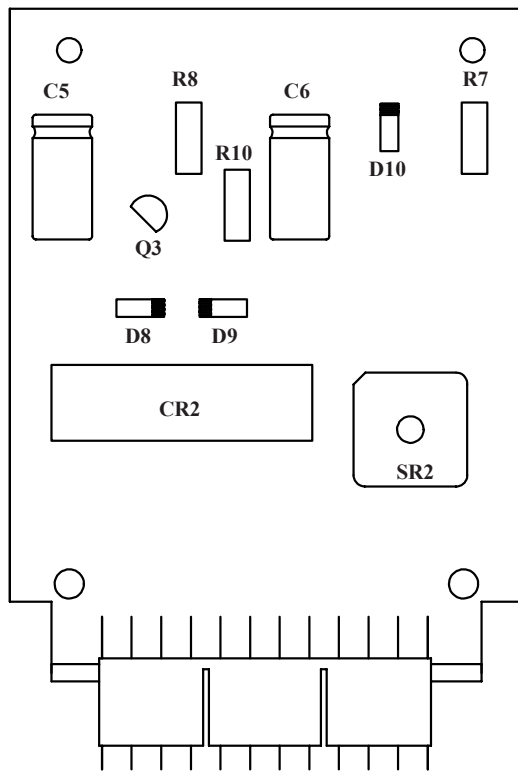

FIGURE D1 - PRINTED CIRCUIT BOARD (SN-529U)

FIGURE D1

ITEM NO.	DIA. MKGS.	PART NO.	DESCRIPTION	QTY.
C5,6	MI-143		CAPACITOR, 47uFD 50V	2
CR2	HG-576		RELAY, 24VDC 4PDT	1
D8,9,10	HG-579		DIODE, 2A	3
Q3	MI-627		TRANSISTOR, PUT	1
R7	MI-125		RESISTOR, 4.7K OHM 1/2W	1
R8	MI-148		RESISTOR, 1.2K OHM 1/2W	1
R10	MI-126		RESISTOR, 3.3K OHM 1/2W	1
SR2	CB-048		RECTIFIER, BRIDGE	1

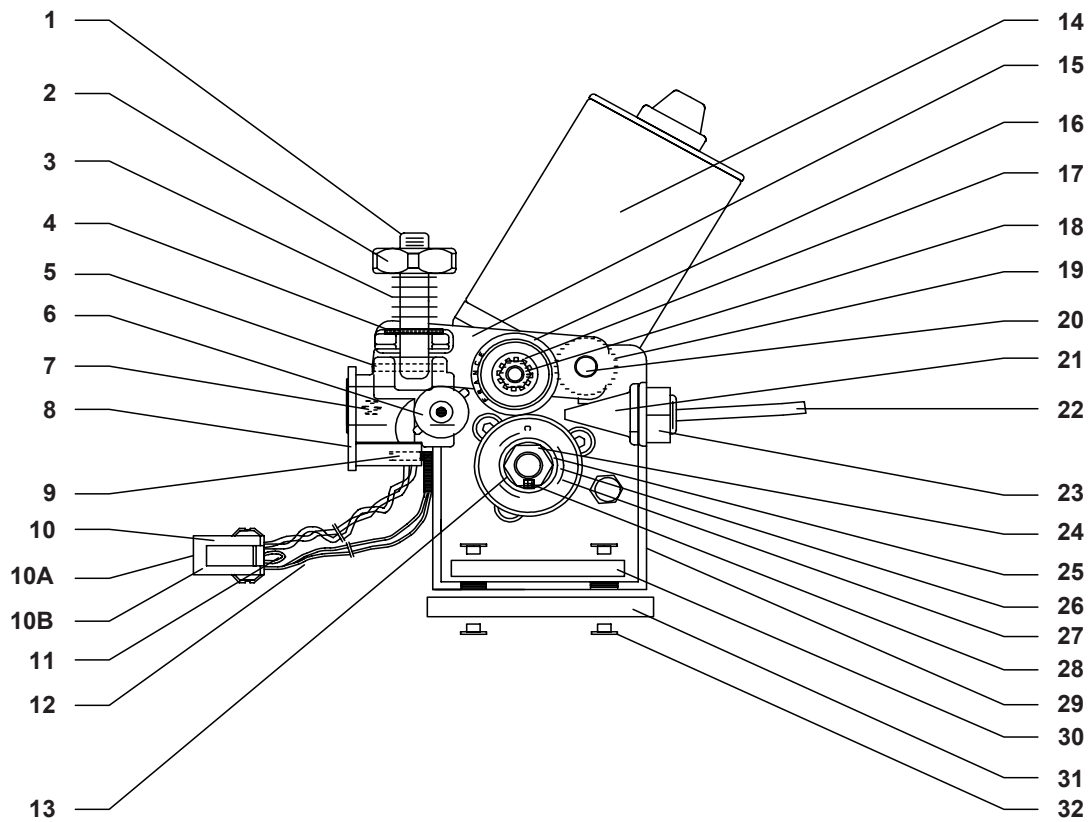

FIGURE D2 - WIRE DRIVE ASSEMBLY (SN-138C24M)

FIGURE D2

ITEM NO.	DIA. MKGS.	PART NO.	DESCRIPTION	QTY.
1		SN-48	PRESSURE ROLL TENSION BOLT	1
2		SN-51	TENSION NUT	1
3		SN-50F	PRESSURE SPRING	1
4		SN-49	TENSION BOLT WASHER	1
5		SN-47	TENSION BOLT PIN	1
6		M3-906	THUMB SCREW	1
7		SN-24	GAS FITTING (2291, 1192) (BEHIND)	1
8		M3-900C	TORCH PANEL MOUNT (HG-525)	1
9		SN-604	WIRE CONNECTOR, 90 DEG.	2
10	RC5	SN-860C	FUNCTION PLUG ASSEMBLY	1
10A		SN-860	PIN HOUSING	1
10B		SN-860M	MALE PIN CONNECTOR	6
	RC6	SN-861C	FUNCTION RECEPTACLE ASSEMBLY (NOT SHOWN)	1
11	J1	AD-10	JUMPER	1
12		SN-237	CONTROL WIRE ASSEMBLY	2
13		SN-65	DRIVE ROLL LOCK WASHER	1
14	M	SN-138C24	24VDC MOTOR	1
15		SN-53F	ROCKER ARM	1
16		SN-158	PRESSURE ROLL	1
17		SN-55F	BEARING SPACER (BEHIND)	1
18		HW-1420KHN	1/4-20 KEP NUT	1
19		SN-89	SPRING WASHER (BEHIND)	1
20		SN-52	SHOULDER BOLT	1
21		SN-33F	INLET GUIDE	1
22		SN-136C	INLET GUIDE TUBE	1
23		SN-34	NUT, INLET GUIDE	1
		HW-58ILW	LOCK WASHER, INTERNAL	1
24		SN-64	DRIVE ROLL NUT	1
25		SN-62	DRIVE ROLL WASHER	1
26		SN-603	ADJUSTING COLLAR (BEHIND)	1
27		SN-60	DRIVE ROLL (30-45DR)	1
28		SN-61C	1/2 WOODRUFF DRIVE KEY	1
29		SN-131S	MOTOR BRACKET, ADJUSTABLE	1
30		SN-139AD	INSULATOR, TOP	1
31		SN-139	MOTOR BASE INSULATOR	1
32		SN-40	INSULATING WASHER	4

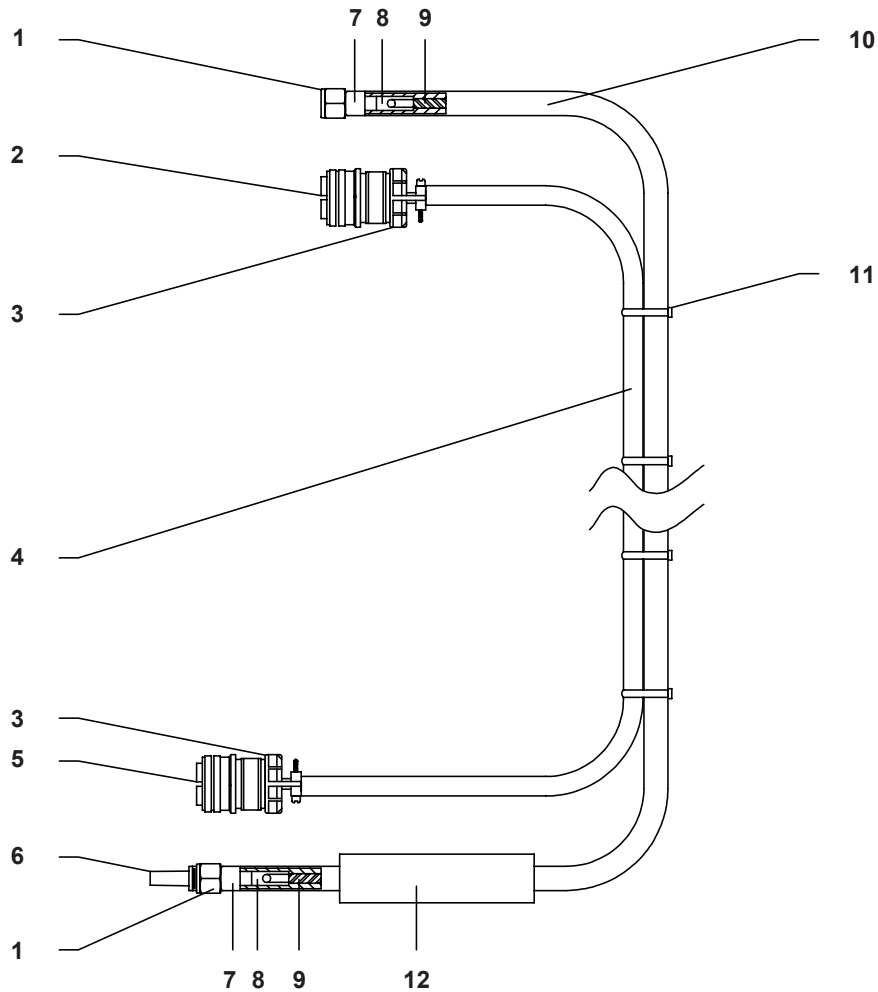
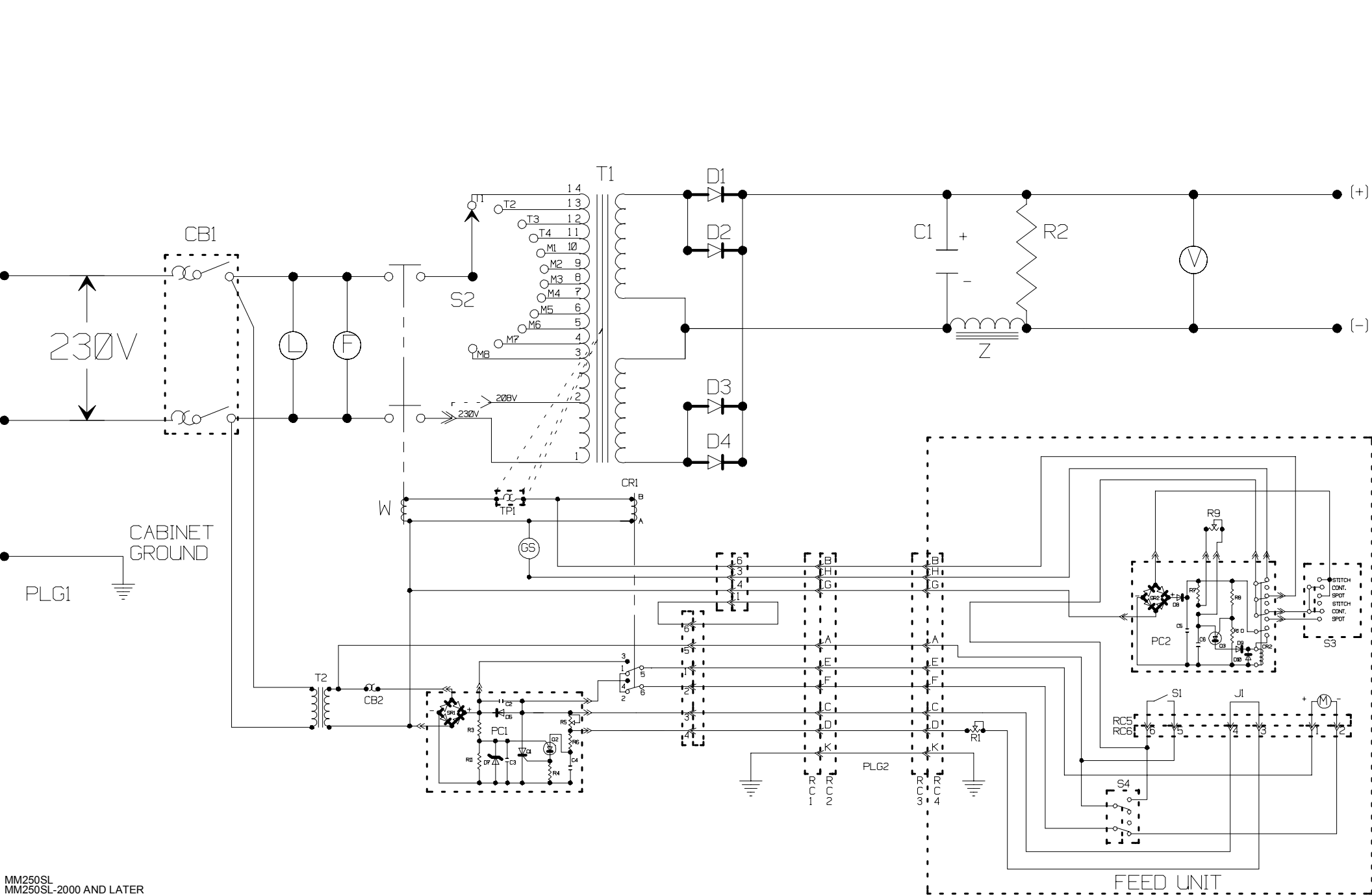

FIGURE E - FEEDER CABLE ASSEMBLY (FCA-15)

FIGURE E

ITEM NO.	DIA. MKGS.	PART NO.	DESCRIPTION	QTY.
1		SN-026	NUT, GAS HOSE	2
2	RC3	SN-6204	PLUG, 14 PIN (FEMALE PINS)	1
3		SN-6204B	CLAMP, 14 PIN PLUG	2
4	PLG2	CC-300-15	CONTROL CABLE ASSY., 15' 14 PIN	1
		SN-6209-15	CABLE ONLY, 15'	1
5	RC2	SN-6191B	PLUG, 14 PIN (MALE PINS)	1
6		PS-4A	POWER PLUG W/GAS HOLE	1
7		SN-028	FERRULE, HOSE	2
8		SN-025	CABLE FITTING	2
9		SN-023	WELD CABLE ONLY (14'-10")	1
10		SN-2157E-15	GAS/CURRENT CABLE ASSY., 15' EXTENSION	1
		SN-027-15	GAS HOSE ONLY, 15'	1
11		SN-2008	CABLE TIE	15
12		SN-807G	BOOT/CABLE COVER	1



MM250SL
MM250SL-2000 AND LATER